

Chapter 1

General

1.1 Background

The first work of code division multiple access was published in 1935 by professor Dmitriy V. Ageev[1]. The technology of CDMA was used in 1957. In the era of CDMA application the schemes combining OFDM and Code division were proposed in 1993. These schemes were developed by several researchers [2]. N.Yee, J-P. Linnartz and G.Fettweis, A.Chouly, A.Brajaj and S.Jourdan developed the MC-CDMA; V.DaSilva and E.S.Sousa developed Multicarrier DS-SS-CDMA and MT-SS-CDMA was developed by L.Vandendorpe.

The first CDMA networks were commercially launched in 1995, and provided about 10 times more capacity than analog networks which was far more than TDMA or GSM.

The world's first cellular networks were introduced in the early 1980s, using analog radio transmission technologies such as AMPS (Advanced Mobile Phone System). But the systems began to hit a capacity ceiling as millions of new subscribers signed up for service, demanding more and more airtime. As a result dropped calls and network busy signals became common problems in many areas. To accommodate more traffic, the industry developed a new set of digital wireless technologies called TDMA (Time Division Multiple Access) and GSM (Global System for Mobile). But just as TDMA was being standardized, an even better solution was found in CDMA. Since then, CDMA has become the fastest-growing of all wireless technologies, with over 100 million subscribers worldwide. In addition to supporting more traffic, CDMA brings many other benefits to carriers and consumers, including better voice quality, broader coverage and stronger security. CDMA consistently provides better capacity for voice and data communications than other commercial mobile technologies, allowing more subscribers to connect at any given time, and it is the common platform on which 3G technologies are built.

Basically CDMA is a "spread spectrum" technology, allowing many users to occupy the same time and frequency allocations in a given band or space. CDMA assigns unique codes to each communication to differentiate it from others in the same spectrum, as its name implies. All of the users transmit in the same wide-band chunk of spectrum. Each

user's signal is spread over the entire bandwidth by a unique spreading code. At the receiver, that same unique code is used to recover the signal. Because CDMA systems need to put an accurate time-stamp on each piece of a signal, it references the GPS system for this information. Between eight and 10 separate calls can be carried in the same channel space as one analog AMPS call.

1.2 Introduction

Code division multiple access (CDMA) is a radio communication technique to allow multiple users to share the same spectrum simultaneously. It is the most investigated application of spread spectrum techniques [3]. In DS-SS (direct-sequence code division multiple access), the narrowband message is multiplied by a large bandwidth signal, which is called the spreading signal. The spreading signal is generated by convolving a pseudo-noise (PN) code with a chip waveform whose duration is much smaller than the symbol duration [3]. By assigning different code sequences to each user, it is possible to allow many users to share the same channel and frequency simultaneously [3]. However an approximate orthogonality constraint on the code sequence is employed to guarantee acceptable performance [4]. Since PN codes are used and synchronization of user signals is not possible, it is not possible to achieve perfect orthogonality between the spreading sequences of different users, therefore the signal of another user may appear as noise in some other user's signal. This phenomenon is called the multiple access interference (MAI) which causes degradation in system performance and bit error rate (BER).

It is multiple access interference (MAI) which is a factor that limits the performance and capacity of direct sequence CDMA systems and refers to the interference between direct sequence users. This interference is the result of the random time offsets between signals, which make it impossible to design code waveforms to be completely orthogonal. While the MAI caused by any one user is generally small, as the number of interferers or their power increases, MAI becomes substantial. Therefore, any analysis of performance of a CDMA system has to take into account the amount of MAI and its effects on the parameters that measure the performance most notably the signal-to-interference-and-noise ratio (SINR) at the receiver and the related bit error probability on the information bit stream. Much work has been reported on the calculation of the

user average bit error rate (BER) for DS-CDMA systems [5]. The most widely used and popular approach is the Gaussian approximation (GA) [6] and its variants.

Mobile communications are rapidly becoming more and more necessary for everyday activities. With so many users to accommodate, more efficient use of bandwidth is a priority among cellular phone system operators. Equally important is the security and reliability of these calls. One solution that has been offered is a Code Division Multiple Access system [7, 8]. Code Division Multiple Access (CDMA) is combined with multi carrier modulation (MCM) several times in wireless communications systems. It is a form of multiplexing that allows multiple signals to use the same transmission channel for transmission. DS-CDMA hence utilizes the bandwidth to the highest level [9]. The performance of quasi synchronous (QS) CDMA will be as good as or slightly better than the synchronous performance of direct sequence DS-CDMA when the maximal allowed time offset does not need to be less than 0.2 for rectangular and 0.7 for raised-cosine chip waveform [10]. There has been a significant amount of research conducted on CDMA since it is widely used in wireless communication systems [11]. Since CDMA radio cellular system capacity is interference limited, power control and code allocation must be managed efficiently in order to control the interference and to guarantee the required quality of service of users. Power control is a key issue to improve the system's capacity [12].

Third generation or 3G, which is built on CDMA, is now the generally accepted term used to describe the next wave of mobile networks and services. First generation (1G) is used to categorize the first analogue mobile systems to emerge in the 1980s, such as the advanced mobile phone system (AMPS) and Nordic mobile telephony (NMT). These systems provided a limited mobile solution for voice, but have major limitations, particularly in terms of interworking, security and quality. The next wave, second generation (2G), arrived in the late 1980s and moved towards a digital solution which gave the added benefit of allowing the transfer of data and provision of other non-voice services. Of these, the global system for mobile communication (GSM) has been the most successful, with its global roaming model. 3G leverages on the developments in cellular to date, and combines them with complementary developments in both the fixed-line telecoms networks and from the world of the Internet. The result is the development of a more general purpose network, which offers the flexibility to provide and support

access to any service, regardless of location. These services can be voice, video or data and combinations thereof, but the emphasis is on the service provision as opposed to the delivery technology [13, 14]. In frequency-division-multiple-access (FDMA) and time-division-multiple-access (TDMA) cellular systems, interference is controlled by assigning disjoint frequency or time slots to all users in the same cell and disjoint frequency bands to adjacent cells. But to increase capacity, frequency bands should be reused for sufficiently separated cells. With direct sequence spread spectrum CDMA, frequency reuse is universal, with the same band utilized by all users over all cells with all user signals appearing as noise to all other users' receivers, progressively more attenuated with the distances involved. Careful analyses of both forward and reverse link interference lead to capacity estimates considerably higher than those for FDMA and TDMA systems, as well as a soft capacity limit unattainable with the more conventional systems [15, 16].

This thesis is a study of the performance of DS-CDMA system with perfect power control where the standard Gaussian approximation (SGA) is used to evaluate bit error rate. Error probabilities for various unbalanced DS-CDMA systems were calculated before using the SGA (improved Gaussian approximation). It was shown that the improved Gaussian approximation gives more accurate results for a scarcely populated system [17]. It was also shown in cellular CDMA systems that the performance and maximum transmission rate of systems degrade with an increase in the number of simultaneous users and the number of interfering cells [18]. The overall error rate can be expressed by a single integral whose integrand is nonnegative and exponentially decaying in a binary direct-sequence spread-spectrum multiple-access system with random sequences in flat Rayleigh fading [19]. Bit error rate (BER) is the parameter, gives an excellent indication of the performance of a data link. In any data link one of the main parameters of interest is the number of errors that occur. So in any evaluation the bit error rate is a key parameter. Knowledge of the BER enables other features of the link such as the power and bandwidth. When the medium between a transmitter and a receiver is good enough, the signal to noise ratio (SNR) will be high and BER will be very much small. Small BER detects a good transmission medium with small noise.

1.3 Technology Description of DS-CDMA

In the DS-CDMA system, two-step modulation and demodulation are logically conducted for both transmission and reception. First, the transmission side conducts the primary signal modulation and creates special waveforms, which is then transmitted via broadband spectrum spread. As the reception side also receives communications signals other than the required signals, it restores the base-band waveform by restoring only the required signals to the original primary modulated signals by reverse-spread using the same spread codes as those on the transmission side. Our thesis work is based on techniques such as Direct Sequence (DS) CDMA. In this technique the spread spectrum transmission is used where the data user signal is multiplied by the code sequence. The duration of each element in that code is called the chip time. The ratio between the user symbol time and the chip time is called the spread factor. The bandwidth occupied by the transmitted signal is known as the product of spread factor and bandwidth used by the user data signal. In the receiving end the signal is multiplied again by the same synchronized code. In this step the code is removed by decoding and thus we get our desired signal [7].

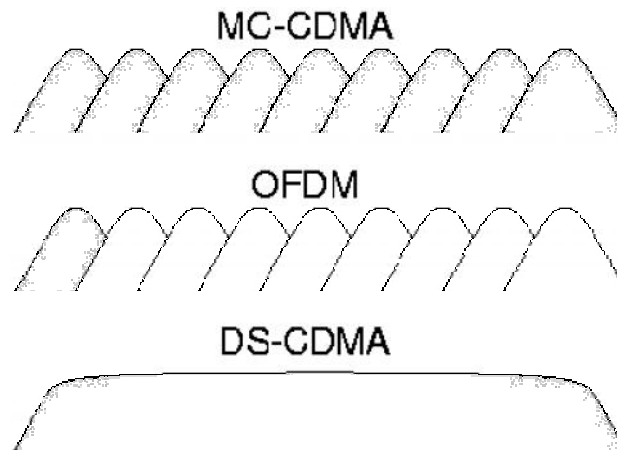

Figure 1.1. Comparison between various CDMA techniques

The spectrum DS-CDMA is extremely expensive; it has to be purchased from various governmental licensing authorities at auction and sometimes those auctions have involved billion of US dollars or equivalent monetary value in other currencies. Therefore, the bandwidth efficiency of a technology should be the primary concern. It is known that the average transmit power level in a DS-CDMA mobile terminal is only about one third of

that required at a TDMA terminal. From the health point of view, the application of DS-CDMA technology is far more attractive than any other air-link technology.

1.4 Implementing CDMA Technology

CDMA works on Information data from several possible sources, such as digitized voice or ISDN channels. Data rates can vary, here are some examples:

Table 1-1: Sources and Data rate

Data Source		Data Rate
Voice	Pulse Code Modulation (PCM)	64 kbits/sec
	Adaptive Differential Pulse Code Modulation (ADPCM)	32 kbits/sec
	Low Delay Code Excited Linear Prediction (LD-CELP)	16 kbits/sec
ISDN	Bearer Channel (B-Channel)	64 kbits/sec
	Data Channel (D-Channel)	16 kbits/sec

The system works with 64 kbits/sec data, but can accept input rates of 8, 16, 32, or 64kbits/sec. Inputs of less than 64 kbits/sec are padded with extra bits to bring them up to 64 kbits/sec.

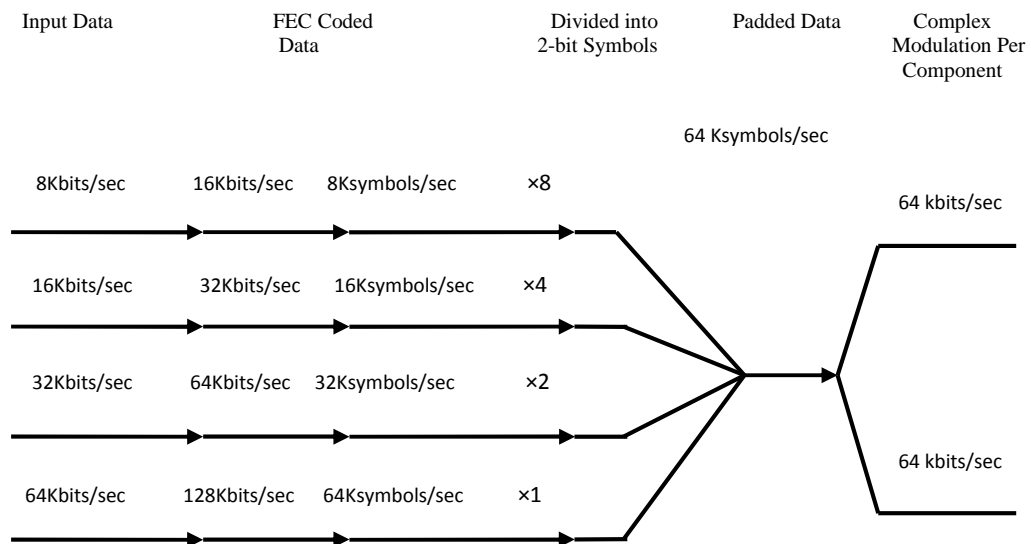

Figure 1.2. Input data rate

For inputs of 8, 16, 32, or 64 kbits/sec, the system applies Forward Error Correction (FEC) coding, which doubles the bit rate, up to 128 kbits/sec. The Complex Modulation scheme transmits two bits at a time, in two bit symbols. For inputs of less than 64 kbits/sec, each symbol is repeated to bring the transmission rate up to 64

kilosymbols/sec. Each component of the complex signal carries one bit of the two bit symbol at 64 kbits/sec as shown in figure 1.2.

1.5 Rayleigh Fading

The Rayleigh fading model is normally viewed as a suitable approach to take when analyzing and prediction radio wave propagation performance for areas such as cellular communications in a well built up urban environment where there are many reflections from buildings and others. High frequency ionospheric radio wave propagation where reflections (or more exactly refractions) occur at many points within the ionosphere is also another area where Rayleigh fading model applies well. It is also appropriate to use the Rayleigh fading model for tropospheric radio propagation because, again there are many reflection points and the signal may follow a variety of different paths. The Rayleigh propagation model is most applicable to instances where there are many different signal paths, none of which is dominant. In this way all the signal paths will vary and can have an impact on the overall signal at the receiver. The Rayleigh fading model is particularly useful in scenarios where the signal may be considered to be scattered between the transmitter and receiver. In this form of scenario there is no single signal path that dominates and a statistical approach is required to the analysis of the overall nature of the radio communications channel.

Rayleigh fading is a model that can be used to describe the form of fading that occurs when multipath propagation exists. In any terrestrial environment a radio signal will travel via a number of different paths from the transmitter to the receiver. The most obvious path is the direct, or line of sight (LOS) path. However there will be very many objects around the direct path. These objects may serve to reflect, refract, etc the signal. As a result of this, there are many other paths by which the signal may reach the receiver. When the signals reach the receiver, the overall signal is a combination of all the signals that have reached the receiver via the multitude of different paths that are available. These signals will all sum together, the phase of the signal being important. Dependent upon the way in which these signals sum together, the signal will vary in strength. If they were all in phase with each other they would all add together. However, this is not normally the case, as some will be in phase and others out of phase, depending upon the various path lengths, and therefore some will tend to add to the overall signal,

whereas others will subtract. As there is often movement of the transmitter or the receiver this can cause the path lengths to change and accordingly the signal level will vary. Additionally if any of the objects being used for reflection or refraction of any part of the signal moves, then this too will cause variation. This occurs because some of the path lengths will change and in turn this will mean their relative phases will change, giving rise to a change in the summation of all the received signals.

Therefore, the Rayleigh fading model can be used to analyze radio signal propagation on a statistical basis. It operates best under conditions when there is no dominant signal (e.g. direct line of sight signal), and in many instances cellular telephones being used in a dense urban environment fall into this category. Other examples where no dominant path generally exists are for ionospheric propagation where the signal reaches the receiver via a huge number of individual paths. Propagation using tropospheric ducting also exhibits the same patterns. Accordingly all these examples are ideal for the use of the Rayleigh fading or propagation model.

1.6 Previous Work

The previous works influenced us in this thesis are as follow:

(a) In August 1994, O.K Tonguz M.M Wang worked on “Cellular CDMA networks impaired by Rayleigh fading: System performance with power control,” IEEE Transactions on Veh. Technol. vol. 43, pp. 515-527. In this paper the effect of power control on the performance of cellular CDMA networks is investigated. Their work shows the dependence of performance gain on the different user spatial distributions under power control. Also, it is shown that power control in the forward link of CDMA networks may lead to dismal performance degradation for close-in users.

(b) In May 1997, K. L. Cheah, S. W. Oh, and K. H. Li worked on “Efficient performance analysis of asynchronous cellular CDMA over Rayleigh-fading channels,” IEEE Commun. Letters, vol. 1, pp. 71-73. The BER analysis of a DS-SS-CDMA cellular system over a Rayleigh-fading channel often results in complicated expressions. In this paper the BER expression is simplified and the complexity is removed by proposing a combined probability density function (pdf) approach for the forward link and a mean-method technique for the reverse

link.

(c) In March 1992, J. M. Holtzman worked on “A simple, accurate method to calculate spread-spectrum multiple-access error probabilities,” IEEE Transactions on Communications, vol. 40, no. 3, pp. 461-464. In this paper the author derives an accurate Gaussian approximation which is computationally very simple. It presents an improved Gaussian approximation with good accuracy.

(d) In October 1989, R. K. Morrow Jr., and J. S. Lehnert worked on “Bit-to-bit error dependence in slotted DS/SSMA packet systems with random signature sequences,” IEEE Transactions on Communications, vol. 37, no. 10, pp. 1052 - 1061, In this paper a technique is developed to find an accurate approximation to the probability of data bit error and the probability of packet success in a direct-sequence spread-spectrum multiple-access (DS/SSMA) packet radio system with random signature sequences.

(e) In January 2002, J. Cheng, and N. C. Beaulieu worked on “Accurate DS-CDMA bit-error probability calculation in Rayleigh fading,” IEEE on Wireless Communications, vol.1, no. 1, pp. 3-15 . Here a binary direct-sequence spread-spectrum multiple-access system with random sequences in flat Rayleigh fading is considered and the results are used to examine definitively the validity of three Gaussian approximations and to compare the performances of synchronous systems to asynchronous systems.

The papers given above inspired us mostly to work on DS-CDMA technology which is an advantageous technology of modern mobile communication.

1.7 Objective and Outline

The objectives of this thesis work are:

- (a) To obtain the analytical expressions of DS-CDMA in the presence of Rayleigh fading.
- (b) To evaluate the performances of bit error rate (BER) over the fading channel with perfect power control.
- (c) To determine the limitations of the system BER on the signal amplitude and SNR
- (d) To determine the optimum system design parameters.

The thesis is organized as follow: In chapter 1 the subject is introduced. In chapter 2 literature survey is presented. Application and limitation of DS-CDMA is discussed in chapter 3. In Chapter 4 performance of DS-CDMA is presented on various parameters. Chapter 5 contains the result and discussions. Chapter 6 concludes the thesis and future works are outlined. In the end of the thesis references are included.

Chapter 2

Literature Survey

2.1 Multiple Access Technique

In wireless communication, limited or finite numbers of radio channels are available and to share these channels simultaneously to many mobile users, Multiple Access Techniques are used. A channel can be defined as a portion of the limited radio resource, which is temporarily allocated for a specific purpose or user, such as someone's phone call. A multiple access method is a definition of how the radio spectrum is divided into channels and how the channels are allocated to the many users of the system. The features of multiple access techniques are:

- (a) It shares many users at same time
- (b) It shares a finite amount of radio spectrum
- (c) High performance
- (d) Duplexing generally required
- (e) It works in frequency domain
- (f) It also works in time domain

A channel-access scheme is based on a multiple access protocol and control mechanism, also known as media access control (MAC). This protocol deals with issues such as addressing, assigning multiplex channels to different users, and avoiding collisions. The MAC-layer is a sublayer in Layer 2 (Data Link Layer) of the OSI model and a component of the Link Layer of the TCP/IP model.

2.1.1 Types of Multiple Access Techniques

There are three major access techniques. They are:

- (a) Frequency Division Multiple Access (FDMA)
- (b) Time Division Multiple Access (TDMA)
- (c) Code Division Multiple Access (CDMA)
- (d) Space Division Multiple Access (SDMA)

2.1.2 FDMA

FDMA is the process of dividing one channel or bandwidth into multiple individual bands, each for use by a single user. Each individual band or channel is wide enough to

accommodate the signal spectra of the transmissions to be propagated.

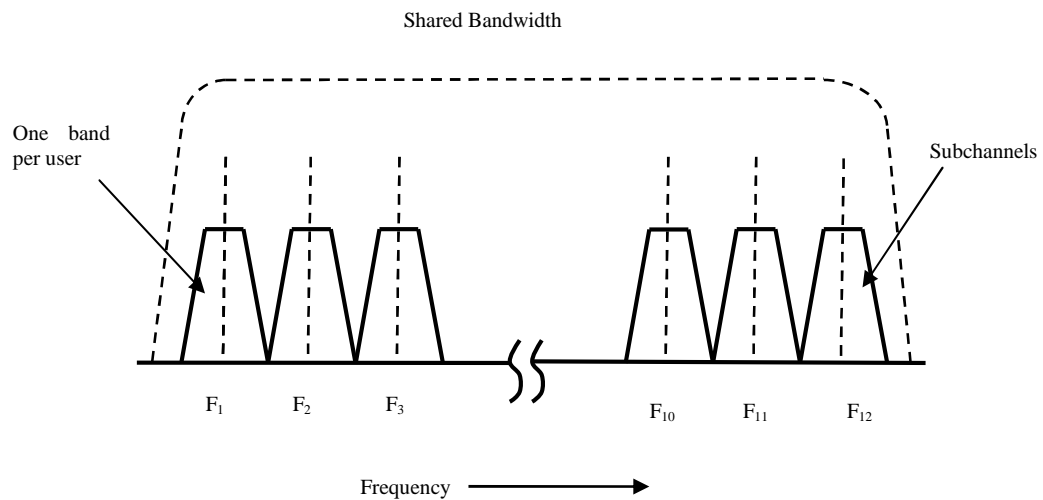

Figure 2.1. FDMA divides the shared medium bandwidth into individual channels

The data to be transmitted is modulated on to each subcarrier, and all of them are linearly mixed together.

2.1.2.1 Advantages of FDMA

The advantages of FDMA are given below:

- (a) FDMA technique doesn't need any base-control station.
- (b) Data that transferred between each station to another during the transmission process will not be lost.
- (c) After the transmission of data, the effect of the delay distortion will be so small and it can be ignored.
- (d) There is no need for network timing.
- (e) In FDMA, the reduction of the information bit rate has a good effect on the capacity.

2.1.2.2 Disadvantages of FDMA

The disadvantages of FDMA are given below:

- (a) In the FDMA technique, it is impossible for the stations to receive data from more than one transmission source.
- (b) One of most important thing in communication systems is the maximum data rate which is small and fixed for every channel in FDMA.
- (c) Because of the guard bands, the capacity of the FDMA will be decreased.

- (d) FDMA requires special filters to avoid any interference between the narrow channels.

2.1.3 Time Division Multiple Access (TDMA)

TDMA works by dividing a radio frequency into time slots and then allocating slots to multiple calls. In this way, a single frequency can support multiple, simultaneous data channels. The users transmit in rapid succession, one after the other, each using its own time slot. This allows multiple stations to share the same transmission medium (e.g. radio frequency channel) while using only a part of its channel capacity.

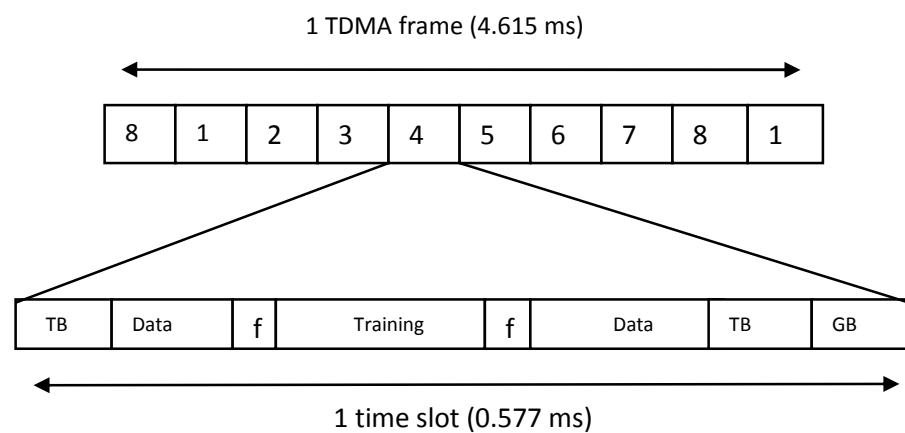

Figure 2.2. GSM TDMA structure

Where, TB=Tail Bits, F=flag, GB=guard band

2.1.4 Code Division Multiple Access (CDMA)

CDMA is a digital wireless technology that uses spread spectrum techniques. Unlike competing systems, such as GSM, CDMA does not assign a specific frequency channel or time slot to each user but instead individual conversations are encoded with a pseudo-random digital sequence. It allows many users to occupy the same space, time and frequency allocations in a given band or space.

CDMA employs analog to digital conversion (ADC) in combination with spread spectrum technology. Audio input is first digitized into binary elements. The frequency of the transmitted signal is then made to vary according to a defined pattern (code), so it can be intercepted only by a receiver whose frequency response is programmed with the same code, so it follows exactly along with the transmitter frequency. There are trillions

of possible frequency-sequencing codes, which enhance privacy and makes cloning difficult.

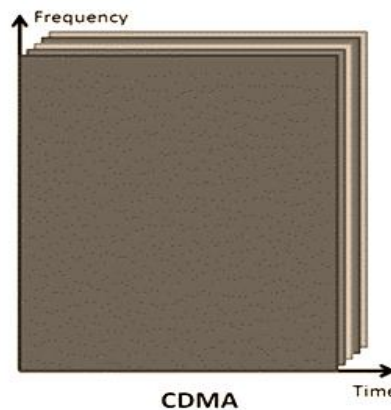

Figure2.3. Code division multiple access

An analogy to the problem of multiple access is a room (channel) in which people wish to communicate with each other. To avoid confusion, people could take turns speaking (time division), speak at different pitches (frequency division), or speak in different languages (code division). CDMA is analogous to the last example where people speaking the same language can understand each other, but not other people. Similarly, in radio CDMA, each group of users is given a shared code. Many codes occupy the same channel, but only users associated with a particular code can understand each other.

CDMA, as its name implies, users' signals are isolated not by separate time or frequency slots, which are occupied in common by all users, but rather by unique underlying codes, which when decoded restore the original desired signal while (ideally) totally removing the effect of the other users' coded signals. For this ideal case the codes must be time-synchronized and orthogonal, meaning that any two users' codes must differ in half their symbols and agree in the other half. This characteristic and particularly synchronization in time is easily achieved for code division multiplexing, where all sources destined for all users are transmitted from the same location, such as a base station. For multiple accesses, on the other hand, time synchronization is generally not practical since users are separated in distance which will change with motion; additionally, multipath may produce different time shifted replicas of each user's transmitted signal and code. Thus for CDMA, users' codes are generally chosen to be non-repetitive over a very long

period, which does not guarantee orthogonality over the shorter period of each user's transmission, but does ensure a small effect on the demodulators of other users.

An important side effect of code division is that each user's transmitted bandwidth is greatly enlarged by making the coded signal's symbol rate, or clock, run much faster than the digital data rate of the source. For example, if the data rate is 10 Kbits/sec, the code clock symbol rate may be 1Mbit/sec or 100 times as fast. The result is an occupied bandwidth approximately equal to the coded rate; hence the term "Spread Spectrum" is often used interchangeably with CDMA.

As early as World War II but with greater intensity and sophistication beginning in the 1950's, spread spectrum was employed in military communications to protect against hostile interception and interference or jamming. For if the enemy does not know the communicator's code, the latter's signal will appear merely as noise. More significantly, if the enemy tries to jam the transmission with any form of radio signal, the intended friendly receiver's demodulator in the process of decoding the desired signal will transform the hostile signal into a spread spectrum form approximating wideband noise. The effect is to reduce the hostile jammer's effectiveness by a factor known as the "processing gain" or "spreading factor" which is the ratio of the code rate to the original source's bit rate (100 for the example just given previously). Measurement accuracy increases with the bandwidth occupied, and spread spectrum helps particularly in identifying, isolating and mitigating multipath propagation. Control is facilitated by the sharing of bandwidth by all users, with an important corollary being the ability to perform soft handover between base stations.

Yet for future so called "Third Generation" services, requiring higher speed wireless data networks, new standards based on CDMA are being universally endorsed by Asian, European and American standards bodies. While the European and Asian versions differ from the North American, mostly in insignificant details, although in one important characteristic (base synchronization), they all benefit from the CDMA advantages described previously.

2.1.5 Space Division Multiple Access (SDMA)

SDMA (Space Division Multiple Access or Spatial Division Multiple Access) is a MIMO (Multiple-Input and Multiple-Output, a multiple antenna schematic architecture)

based wireless communication network architecture, which enables access to a communication channel by identifying the user location and establishing a one-to-one mapping between the network bandwidth division and the identified spatial location. SDMA utilizes the spatial separation of the users in order to optimize the use of the frequency spectrum.

2.2 CDMA Concept

The bits of slow speed data traffic from each subscriber are multiplied by a high chip rate spreading code, $S_k(n)$, forcing the low rate (narrowband data signal) to fill a wide channel bandwidth. Spreading ratios, i.e. ratios of the transmitted (chip) bandwidth to data (bit) bandwidth, are typically 100 – 10,000. Many subscribers can then be accessed by allocating unique, orthogonal, spreading codes, $S_k(n)$.

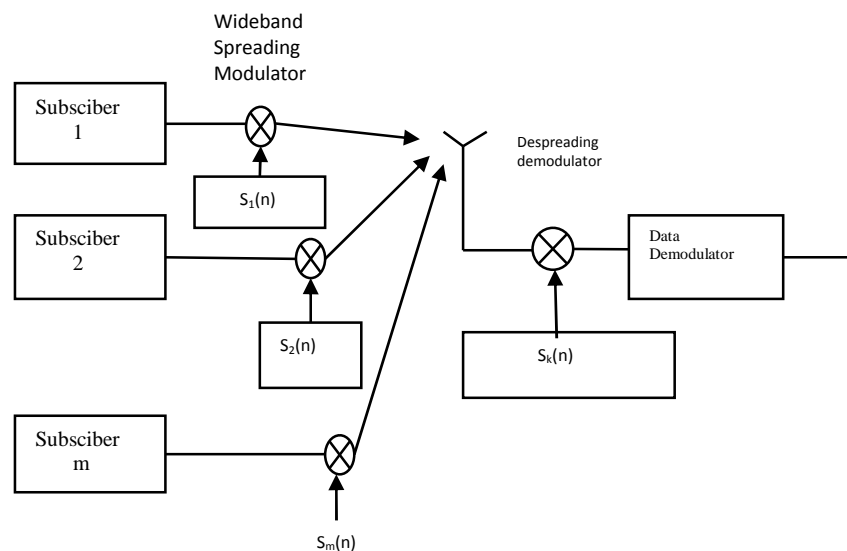

Figure 2.4. Principle of (direct sequence) code division multiple access (CDMA)

2.2.1 Spread Spectrum Communication

The main principle of spread spectrum communication is that the bandwidth occupancy is much higher than usual. Because of this much larger bandwidth the power spectral density is lower, in the channel the signal just looks like noise. The spreading is done by combining the data signal with a code (code division multiple access) which is independent of the transmitted data message. CDMA is a form of Direct Sequence Spread Spectrum communications.

In general, Spread Spectrum communications is distinguished by three key elements:

- (a) The signal occupies a bandwidth much greater than that which is necessary to send the information. This results in many benefits, such as immunity to interference and jamming and multi-user access.
- (b) The bandwidth is spread by means of a code which is independent of the data. The independence of the code distinguishes this from standard modulation schemes in which the data modulation will always spread the spectrum somewhat.
- (c) The receiver synchronizes to the code to recover the data. The use of an independent code and synchronous reception allows multiple users to access the same frequency band at the same time.

In order to protect the signal, the code used is pseudo-random. It appears random, but is actually deterministic, so that the receiver can reconstruct the code for synchronous detection. This pseudo-random code is also called pseudo-noise (PN).

2.2.1.1 The Advantages of the Method

The advantages of spread spectrum are given below:

- (a) As the signal is spread over a large frequency band, the power spectral density is getting very small, so other communications systems do not suffer from this kind of communications. However, the Gaussian noise level is increasing.
- (b) Random access can be dealt with as a large number of codes can be generated and as a result large number of users can be permitted.
- (c) In this technique without knowing the spreading code, it is (nearly) impossible to recover the transmitted data. Hence security is more.

There are couples of spread spectrum techniques which can be used. The most famous one is Direct Sequence (DS).

2.2.2 Why Spread Spectrum

The basic reasons for using spread spectrum are as follow:

- (a) Receiver only detects correctly coded data sequences
- (b) Signal to noise ratio (SNR) gain
- (c) Interference reduction

- (d) (Uncoordinated) multiple access capability
- (e) Wide bandwidth resolves individual multipath responses
- (f) Measure received signal timing

Signal detection is achieved by correlation, against a local reference code, which is identical to the transmitting spread spectrum code. Code orthogonality implies that the output of the correlator is zero for all except the desired transmission. Correlation detection gives a processing gain or SNR improvement, G_p , equal to the spreading ratio:

$$G_p = 10 \log_{10} \left(\frac{\text{transmitted signal bandwidth}}{\text{original data bandwidth}} \right) (dB) = 10 \log_{10} \frac{R_c}{R_b}$$

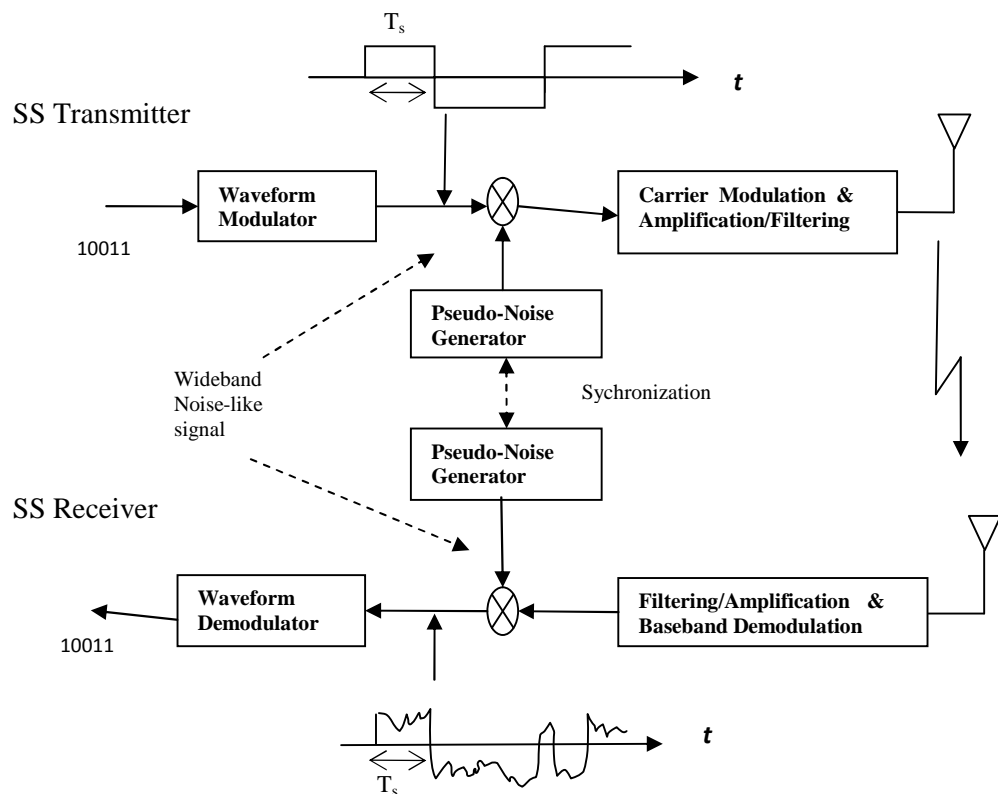

Figure 2.5. Block Diagram of a Spread Spectrum System

Spreading modulation:

Data	+1	+1	+1	1	1	1	+1	+1	+1
Spreading code	+1	1	+1	+1	1	+1	+1	1	+1
Product sequence	+1	1	+1	1	+1	1	+1	1	+1

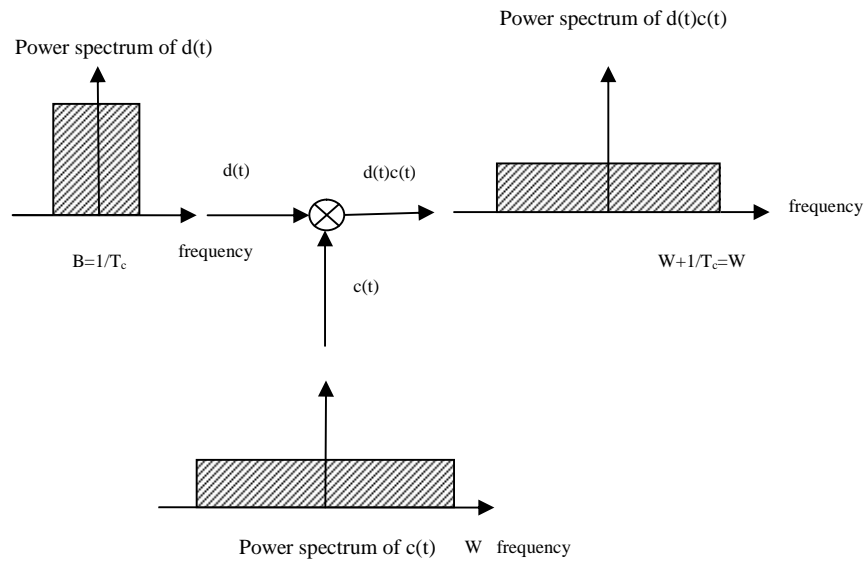

Figure 2.6. Multiplicative Bandwidth Expansion

2.3 Properties of DS- CDMA

Based on analysis of the DS-CDMA system, it can be summarized some properties of DS-CDMA as follows:

2.3.1 Universal Frequency Reuse

As CDMA achieves the orthogonality among the transmitted signals, the total frequency bandwidth allocated to the system can be reused from cell to cell [16]. As a result it's possible to have universal frequency reuse that is a frequency reuse of 1 and maximum frequency reuse. The significantly reduces the complexity of frequency planning in a cellular system design.

2.3.2 Soft Handoff

In cellular telephone communication, soft handoff refers to the overlapping of repeater coverage zones, so that every cell phone set is always well within range of at least one repeater (also called a base station). The act of transferring support of a mobile from one base station to another is termed handoff. In a traditional "hard" handoff, the connection to the current cell is broken, and then the connection to the new cell is made. This is known as a "break-before-make" handoff. Since all cells in CDMA use the same frequency, it is possible to make the connection to the new cell before leaving the

current cell. This is known as a "make-before-break" or "soft" handoff. Soft handoff requires less power, which reduces interference and increases capacity.

2.3.3 High Transmission Accuracy

With spread spectrum we can use Rake receivers to mitigate the fading dispersive channel impairments and therefore improve transmission accuracy, especially during soft handoff.

2.3.4 Soft Capacity

In practice, the PN sequences are not truly orthogonal, MAI will degrade the transmission BER performance. The maximum number of users that can be supported in each cell depends on the required quality of service (QoS) and is limited by MAI. As a result, unlike TDMA and FDMA, there is no hard limit on the number of users in each cell. During peak traffic hours, if the users can tolerate QoS to a certain degree, the system can accommodate more users to satisfy the high service demands in that period.

2.3.5 Flexibility

As CDMA is interference limited, if a user does not transmit, it does not generate any interference with other active users. Therefore, it does not use the system resources. This feature translates to a high resource utilization via statistical multiplexing for on-off voice traffic and bursty data traffic. Even though TDMA can make use of the traffic activity factor to increase resource utilization, with CDMA it is easier to implement the statistical multiplexing. CDMA has more flexibility than TDMA in supporting multimedia services. CDMA provides design freedom and flexibility over narrowband systems, particularly in dense mesh networks.

It was shown that, particularly for terrestrial cellular telephony, the interference-suppression feature of CDMA (code division multiple access) can result in a many-fold increase in capacity over analog and even over competing digital techniques [22]. Augmented and power-controlled multiple-cell CDMA promises a quantum increase in current cellular capacity.

2.4 Different Schemes of CDMA

Multimedia services in a mobile radio communication CDMA is a very vital aspirant since it deals extremely well with the asynchronous nature of multimedia data traffic. To rephrase it provides higher capability over all the common access techniques named Time Division Multiple Access (TDMA), Frequency Division Multiple Access (FDMA). It also counters the channel frequency selectivity. There are four new multiple access schemes based on a combination of code division and OFDM. Such as:

- (a) Multicarrier (MC) CDMA
- (b) Multicarrier DS-CDMA
- (c) Multitone (MT)-CDMA and
- (d) Multicarrier OFDM DS-CDMA

Table 2-1: Comparison between Different CDMA Schemes

Access Scheme	Symbol Duration at Subcarrier	The Number of Subcarrier	Process gain	Chip Duration	Subcarrier Separation	Required Bandwidth
DS-CDMA	T_s	1	G_{DS}	T_s / G_{DS}		G_{DS} / T_s Nyquist Filter with roll-off factor 0
MC-CDMA	T_s	$N_c (= G_{MC})$	$G_{MC} \approx G_{DS}$		$1 / T_s$	$(G_{MC} + 1) / T_s$
Multicarrier DS-CDMA	$N_c T_s$	N_c	$G_{MD} = G_{DS}$	$N_c T_s / G_{DS}$	$G_{DS} / N_c T_s$	$(N_c + 1 / N_c) \times (G_{DS} / T_s)$
MT-CDMA	$N_c T_s$	N_c	$G_{MT} = N_c G_{DS}$	T_s / G_{DS}	$1 / N_c T_s$	$(N_c - 1 / N_c T_c) + 2(G_{DS} / T_s)$

2.5 Wireless Communication Based on CDMA

The world is demanding more from wireless communication technologies than ever before as more people around the world are subscribing to wireless. Add in exciting Third-Generation (3G) wireless data services and applications, such as wireless email, web, digital picture taking or sending, assisted-GPS position location applications, video and audio streaming, TV broadcasting and wireless networks are doing much more than just a few years ago. This is where CDMA technology fits in. CDMA consistently provides better capacity for voice and data communications than other commercial mobile technologies, allowing more subscribers to connect at any given time, and it is the common platform on which 3G technologies are built. In a world of finite spectrum

resources, CDMA enables many more people to share the airwaves at the same time than do alternative technologies.

2.6 CDMA Deployments

CDMA is the fastest growing wireless technology and it will continue to grow at a faster pace than any other technology. Worldwide wireless standard is given below:

Table 2-2: Worldwide Wireless Communication Standard Based on CDMA

Standard	Type	Year	Multiple access	Frequency Band (MHz)	Modulation	Channel Bandwidth (KHz)
IS-95	Cellular/PCS	1993	CDMA	824-894 1800-2000	QPSK/BPSK	1250
CDMA 2000	Cellular	2000	CDMA	450, 800, 1700, 1900, 2100	QPSK	2000

The CDMA air interface is used in both 2G and 3G networks. 2G CDMA standards are branded CDMA One and include IS-95A and IS-95B. CDMA is the foundation for 3G services: the two dominant IMT-2000 standards, CDMA2000 and WCDMA, are based on CDMA [21].

2.6.1 CDMA One: The Family of IS-95 CDMA Technologies

CDMA One describes a complete wireless system based on the TIA/EIA IS-95 CDMA standard, including IS-95A and IS-95B revisions. It represents the end-to-end wireless system and all the necessary specifications that govern its operation. CDMA One provides a family of related services including cellular, PCS and fixed wireless (wireless local loop). CDMA One IS-95B was first deployed in September 1999 in Korea and has since been adopted by operators in Japan and Peru.

2.6.2 IS-95A: The First CDMA Cellular Standard

TIA/EIA IS-95 (Telecommunications Industry Association / Electronic Industries Association Interim Standard - 95) was first published in July 1993. The IS-95A revision was published in May 1995 and is the basis for many of the commercial 2G CDMA systems around the world. IS95A describes the structure of the wideband 1.25 MHz CDMA channels, power control, call processing, hand-offs, and registration techniques

for system operation. In addition to voice services, many IS-95A operators provide circuit-switched data connections at 14.4 kbps. IS-95A was first deployed in September 1995 by Hutchison (HK).

2.6.3 IS-95B: 2.5G

The IS-95B revision also termed TIA/EIA-95, combines IS-95A, ANSI-J-STD-008 and TSB-74 into a single document. TSB-74 describes interaction between IS-95A and CDMA PCS systems that conform to ANSI-J-STD-008. Many operators that have commercialized IS-95B systems offer 64 kbps packet-switched data, in addition to voice services. Due to the data speeds IS-95B is capable of reaching; it is categorized as a 2.5G technology.

2.6.4 2G – CDMA One Advantages

When implemented in a cellular network, CDMA One technology offers numerous benefits to the cellular operators and their subscribers. They are as follow:

- (a) Capacity increases of 8 to 10 times that of an AMPS analog system and 4 to 5 times that of a GSM system
- (b) Improved call quality, with better and more consistent sound as compared to AMPS systems
- (c) Simplified system planning through the use of the same frequency in every sector of every cell
- (d) Enhanced privacy
- (e) Improved coverage characteristics, allowing for the possibility of fewer cell sites
- (f) Increased talk time for portables
- (g) Bandwidth on demand

2.6.5 3G CDMA 2000

Third Generation (3G) is the term used to describe the latest generation of mobile services which provide advanced voice communications and high-speed data connectivity, including access to the Internet, mobile data applications and multimedia content. The International Telecommunication Union (ITU), working with industry standards bodies from around the world, has defined the technical requirements and standards as well as the use of spectrum for 3G systems under the IMT-2000

(International Mobile Telecommunications-2000) program. The ITU requires that IMT-2000 (3G) networks, among other capabilities, deliver improved system capacity and spectrum efficiency over 2G systems and that they support data services at minimum transmission rates of 144 kbps in mobile (outdoor) and 2 Mbps in fixed (indoor) environments. Based on these requirements, in 1999 the ITU approved five radio interface modes for IMT-2000 standards (Recommendation 1457). Three of the five approved standards (CDMA2000, TDSCDMA and WCDMA) are based on CDMA. CDMA2000 is also known by its ITU name, IMT-2000 CDMA Multi-Carrier (MC).

2.6.6 CDMA2000 Technologies

CDMA2000 represents a family of standards and includes:

- (a) CDMA2000 1X
- (b) CDMA2000 1xEV-DO Technologies
 - i. CDMA2000 1xEV-DO Rel 0
 - ii. CDMA2000 1xEV-DO Rev A
 - iii. CDMA2000 1xEV-DO Rev B

CDMA2000 builds on the inherent advantages of CDMA technologies and introduces other enhancements, such as Orthogonal Frequency Division Multiplexing (OFDM), advanced control and signaling mechanisms, improved interference management techniques, end-to-end Quality of Service (QoS) and new antenna techniques such as Multiple Inputs Multiple Outputs (MIMO) and Space Division Multiple Access (SDMA) to increase data throughput rates and quality of service, while significantly improving network capacity and reducing delivery cost.

2.6.7 Key Features of CDMA2000

The key features of CDMA are mainly as follows:

- (a) **Leading performance:** CDMA2000 performance in terms of data-speeds, voice capacity and latencies continue to outperform in commercial deployments other comparable technologies.
- (b) **Efficient use of spectrum:** CDMA2000 technologies offer the highest voice capacity and data throughput using the least amount of spectrum, lowering the cost of delivery for operators and delivering superior customer experience for the end users.

- (c) Support for advanced mobile services: CDMA2000 1xEV-DO enables the delivery of a broad range of advanced services, such as high-performance VoIP, push-to-talk, video telephony, multimedia messaging, multicasting and multi-playing online gaming with richly rendered 3D graphics.
- (d) Devices selection: CDMA2000 offers the broadest selection of devices and has a significant cost advantage compared to other 3G technologies to meet the diverse market needs around the world.
- (e) Seamless evolution path: CDMA2000 has a solid and long-term evolution path which is built on the principle of backward and forward compatibility, in-band migration, and support of hybrid network configurations.
- (f) Flexibility: CDMA2000 systems have been designed for urban as well as remote rural areas for fixed wireless, wireless local loop (WLL), limited mobility and full mobility applications in multiple spectrum bands, including 450 MHz, 800 MHz, 1700 MHz, 1900 MHz and 2100 MHz.

2.6.8 CDMA2000 Advantages

CDMA 2000 advantages [21] are

- (a) Superior Voice Clarity
- (b) High-Speed Broadband Data Connectivity
- (c) Low End-to-End Latency
- (d) Increased Voice and Data Throughput Capacity
- (e) Differentiated Value-Added Services such as VoIP, PTT, Multicasting, Position Location, etc.
- (f) Application, User and Flow-based Quality of Service (QoS)
- (g) Flexible Spectrum Allocations with Excellent Propagation Characteristics
- (h) Robust Link Budget for Extended Coverage and Increased Data Throughputs at the Cell
- (i) Edge
- (j) Multi-mode, Multi-band, Global Roaming
- (k) Improved Security and Privacy
- (l) Lower total cost of ownership
- (m) Flexible Network Architecture with connectivity to ANSI-41, GSM-MAP and IP-based Networks and flexible Backhaul Connectivity

2.7 Multicarrier (MC) CDMA

This scheme involves the original data stream over different subcarriers using a known spreading code in the frequency domain. A portion of the symbol analogous to a chip of the spreading code is transmitted all the way through a different subcarrier. The codes widely used in this scheme are the Hadamard Walsh Codes since the auto-correlation characteristics of the spreading codes are neglected.

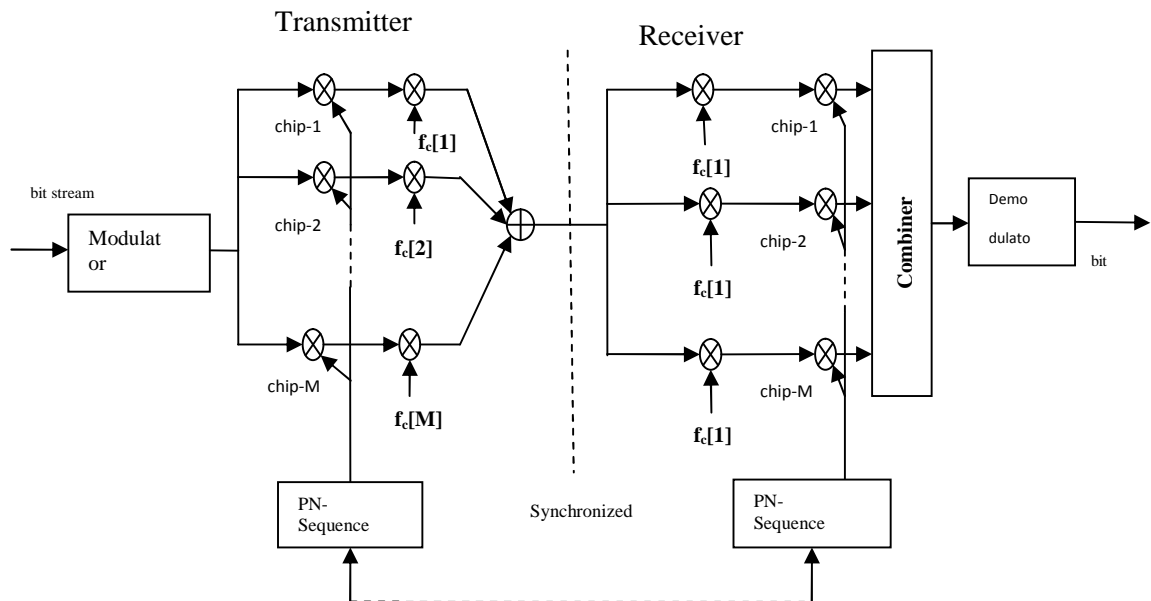

Figure 2.7. Multi carrier CDMA

2.7.1 Multicarrier DS CDMA

In this method the transmitter uses the s/p converter to convert the unique data stream using a given spreading code in the time domain. Hence the resultant spectrum of each subcarrier satisfies the orthogonality with the smallest amount of frequency partition or spacing. This is basically a scheme for the uplink communication channel as the OFDM is initiated in this scheme which is very efficient for launching a quasi-synchronous channel.

2.7.2 Multitone CDMA

The MT-CDMA transmitter spreads the converted data in the time domain using the spreading code so that the each subcarrier is orthogonal and has minimum frequency separation. Hence the resulting spectrum of each of them does not satisfy the orthogonality condition. In this scheme spreading codes of bigger length is used to

transmit the data if compared with a single carrier DS-CDMA scheme. Therefore it can accommodate more users than DS-CDMA scheme.

2.7.3 Multicarrier OFDM DS-CDMA

In this method the transmitter uses the s/p converter to convert the unique data stream using a given spreading code in the time domain. OFDM is a technique which allows the signal to split into several narrowband channels at different frequencies called subcarriers. The space between these frequencies ensures the orthogonality of the technique preventing the demodulators from interference.

2.8 Characteristics of CDMA

The characteristics of CDMA mainly are:

- (a) Spread spectrum techniques use a transmission bandwidth that is several orders of magnitude greater than the minimum required signal bandwidth. These systems were designed using spread spectrum because of its security and resistance to jamming.
- (b) CDMA can effectively reject narrow band interference. Since narrow band interference affects only a small portion of the spread spectrum signal, it can easily be removed through notch filtering without much loss of information.
- (c) CDMA devices use a rake receiver, which exploits multipath delay components to improve the performance of the system.
- (d) In a CDMA system, the same frequency can be used in every cell, because channelization is done using the pseudo-random codes.
- (e) Reusing the same frequency in every cell eliminates the need for frequency planning in a CDMA system.
- (f) CDMA systems use the soft hand off, which is undetectable and provides a more reliable and higher quality signal.

Since the spreading PN sequences are not truly orthogonal, as a multiple access technology CDMA is interference limited. This means that the capacity of CDMA has a soft limit and is a function of the service quality.

2.9 System Description

In Direct Sequence spread spectrum transmission, the user data signal is multiplied by a code sequence. Mostly, binary sequences are used. The duration of an element in the code is called the "chip time".

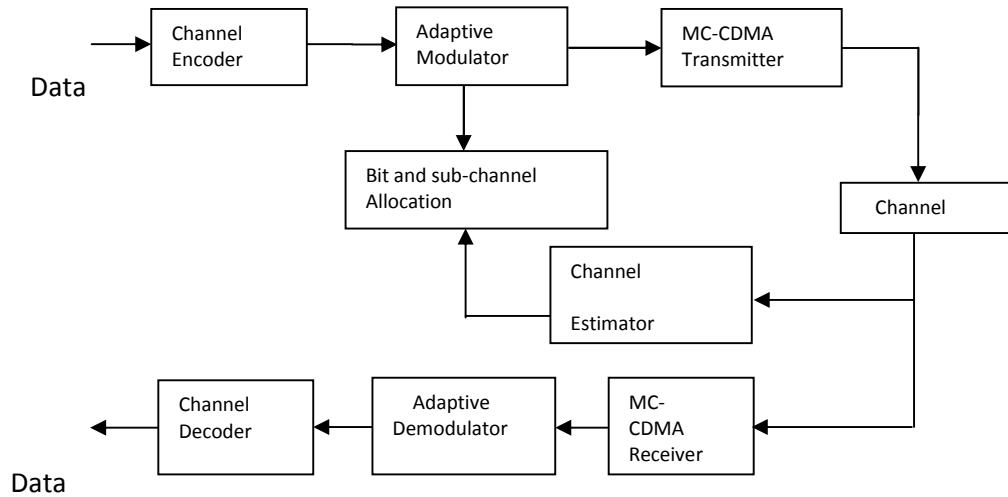

Figure 2.8. MC DS CDMA

The ratio between the user symbol time and the chip time is called the spread factor.

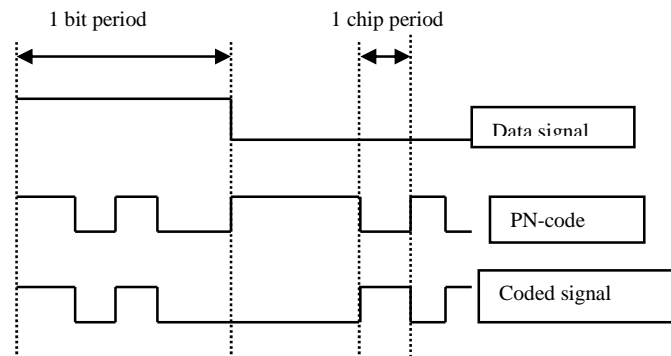

Figure 2.9. A DS-SS signal is generated by multiplication of a user data signal by a code sequence

In the receiver, the received signal is again multiplied by the same (synchronized) code. This operation removes the code, so we recover the transmitted user data (multiplier and integrator) in the receiver. Different CDMA users use different codes. It is well known that one of the major challenges in MC-DS-SS is its stringent power control requirements which limit its performance.

In figure 2.10 the receiver sees the signal from user 1.

$$\sum_{n=1}^N c_1^2(nT_C + t_d) = \sum_{n=1}^N c_1^2(nT_C) = N \quad (2.1)$$

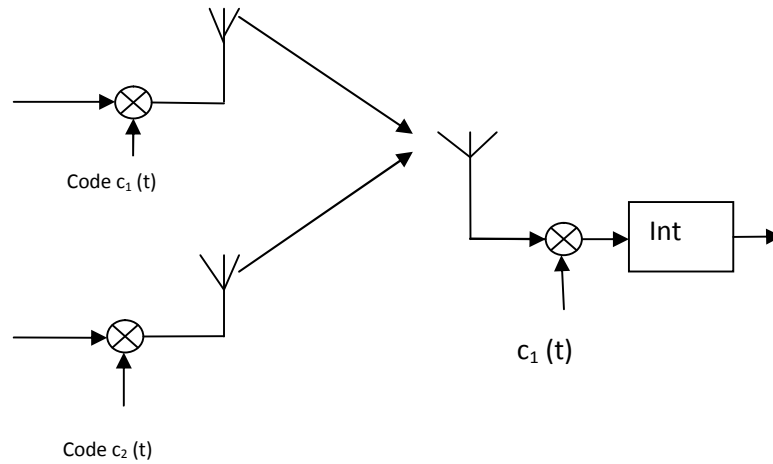

Figure 2.10. DS-SS technique

Where C_1 is the code sequence used by user 1, T_c is the chip duration, t_d is a common time offset, shared between transmitter and receiver and N is the length of the code sequence.

2.10 Frequency Hopping Code Division Multiple Access (FH-CDMA)

FH – CDMA is a kind of spread spectrum technology that enables many users to share the same channel by employing a unique hopping pattern to distinguish different users' transmission.

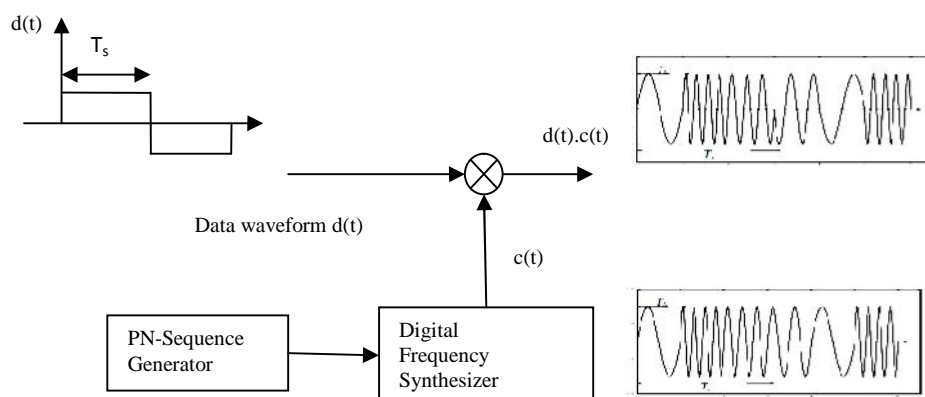

Figure 2.11. Frequency hopping block diagram

The type of spread spectrum in which the carrier hops randomly from one frequency to another is called FH spread spectrum. A common modulation format for FH system is that of M-ary frequency shift keying (MFSK). A major advantage of frequency hopping is that it can be implemented over a much larger frequency band than it is possible to implement DS- spreading, and the band can be noncontiguous. Another major advantage is that frequency hopping provides resistance to multiple access interference (MAI) while not requiring power control to prevent near – far problems. In DS systems, accurate power control is crucial but becomes less effective as the carrier frequency is increased.

2.11 Time Hopping Code Division Multiple Access (TH-CDMA)

Time-hopping (TH) is a communications signal technique which can be used to achieve anti-jamming (AJ) or low probability of intercept (LPI). It can also refer to pulse-position modulation.

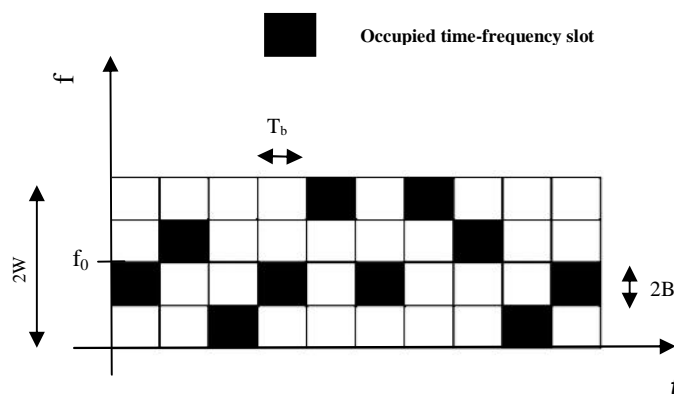

Figure 2.12. Time-frequency occupancy of FH-SS signal

2.12 Bit Error Rate

Bit error rate, BER is a key parameter that is used in assessing systems that transmit digital data from one location to another. When data is transmitted over a data link, there is a possibility of errors being introduced into the system. If errors are introduced into the data, then the integrity of the system may be compromised. As a result, it is

necessary to assess the performance of the system, and bit error rate, BER, provides an ideal way in which this can be achieved.

The definition of bit error rate can be translated into a simple formula:

$$\text{Bit Error Rate, BER} = \frac{\text{Number of Errors}}{\text{Total number of bits sent}}$$

In radio signal paths the main two reasons for the degradation of a data channel and the corresponding bit error rate, BER is noise and changes to the propagation path. Both effects have a random element to them which are discussed in this thesis. The noise following a Gaussian probability functions while the propagation model follows a Rayleigh model. This means that analysis of the channel characteristics are normally undertaken using statistical analysis techniques. In this paper we consider Rayleigh fading channel. Another contributory factor for bit errors is any phase jitter that may be present in the system as this can alter the sampling of the data.

2.13 Factors Affecting Bit Error Rate, BER

It can be seen from using E_b/N_0 , that the bit error rate, BER can be affected by a number of factors. By manipulating the variables that can be controlled it is possible to optimize a system to provide the performance levels that are required. This is normally undertaken in the design stages of a data transmission system so that the performance parameters can be adjusted at the initial design concept stages. The factors are:

- (a) Interference: The interference levels present in a system are generally set by external factors and cannot be changed by the system design. However it is possible to set the bandwidth of the system. By reducing the bandwidth the level of interference can be reduced. However reducing the bandwidth limits the data throughput that can be achieved.
- (b) Increase transmitter power: It is also possible to increase the power level of the system so that the power per bit is increased. This has to be balanced against factors including the interference levels to other users and the impact of increasing the power output on the size of the power amplifier and overall power consumption and battery life, etc.
- (b) Lower order modulation: Lower order modulation schemes can be used, but this is at the expense of data throughput.

(c) Reduce bandwidth: Another approach that can be adopted to reduce the bit error rate is to reduce the bandwidth. Lower levels of noise will be received and therefore the signal to noise ratio will improve. Again this results in a reduction of the data throughput attainable.

Chapter 3

Applications and Limitations of DS-CDMA

3.1 General

CDMA (Code-Division Multiple Access) is a channel access method used by various radio communication technologies. It is a form of multiplexing, which allows numerous signals to occupy a single transmission channel, optimizing the use of available bandwidth. The technology is used in ultra-high-frequency (UHF) cellular telephone systems in the 800-MHz and 1.9-GHz bands. CDMA employs analog-to-digital conversion (ADC) in combination with spread spectrum technology. Audio input is first digitized into binary elements. The frequency of the transmitted signal is then made to vary according to a defined pattern (code), so it can be intercepted only by a receiver whose frequency response is programmed with the same code, so it follows exactly along with the transmitter frequency. There are trillions of possible frequency-sequencing codes, which enhance privacy and makes cloning difficult.

The original CDMA standard, also known as CDMA one and still common in cellular telephones offers a transmission speed of only up to 14.4 Kbps in its single channel form and up to 115 Kbps in an eight-channel form. CDMA2000 and Wideband CDMA deliver data many times faster.

3.2 Direct Sequence Spread Spectrum (DSSS)

Direct sequence spread spectrum (DSSS) is a transmission technology used in local area wireless network transmissions. In this technology, a data signal at the sending station is combined with a high data rate bit sequence, which divides user data based on a spreading ratio. The benefits of using DSSS are resistance to jamming, sharing single channels among multiple users, less background noise and relative timing between transmitter and receivers. This term is also known as direct sequence code division multiple access.

3.2.1 Techopedia Explains Direct Sequence Spread Spectrum (DSSS)

DSSS is a spread spectrum modulation technique used for digital signal transmission over airwaves. It was originally developed for military use, and employed difficult-to-

detect wideband signals to resist jamming attempts. It is also being developed for commercial purposes in local and wireless networks. The stream of information in DSSS is divided into small pieces, each associated with a frequency channel across spectrums. Data signals at transmission points are combined with a higher data rate bit sequence, which divides data based on a spreading ratio. The chipping code in a DSSS is a redundant bit pattern associated with each bit transmitted. This helps to increase the signal's resistance to interference. If any bits are damaged during transmission, the original data can be recovered due to the redundancy of transmission.

The entire process is performed by multiplying a radio frequency carrier and a pseudo-noise (PN) digital signal. The PN code is modulated onto an information signal using several modulation techniques such as quadrature phase-shift keying (QPSK), binary phase-shift keying (BPSK), etc. A doubly-balanced mixer then multiplies the PN modulated information signal and the RF carrier. Thus, the TF signal is replaced with a bandwidth signal that has a spectral equivalent of the noise signal. The demodulation process mixes or multiplies the PN modulated carrier wave with the incoming RF signal. The result produced is a signal with a maximum value when two signals are correlated. Such a signal is then sent to a BPSK demodulator. Although these signals appear to be noisy in the frequency domain, bandwidth provided by the PN code permits the signal power to drop below the noise threshold without any loss of information.

3.3 Pseudo-noise Code

A pseudo-noise code (called PN code in short) has properties similar to a noise sequence. It is actually a regular periodical binary sequence though looking like a noise one. M-sequences are the most important and fundamental among all pseudo-noise codes. Pseudo-noise codes used in a CDMA2000 system are of two types, namely, m-sequence with length $2^{15}-1$ and that with length $2^{42}-1$.

3.4 Perfect Power Control

Since CDMA radio cellular system capacity is interference limited, power control and code allocation must be managed efficiently in order to control the interference and to guarantee the required quality of service of users. Power control is a key issue to improve the system's capacity [12]. The power control system controls transmission

signal power for each cellular mobile telephone in the cellular mobile telephone system. Transmitter power can be adjusted at the mobile unit in an opposite manner with respect to increases and decreases in received signal power. A power control feedback scheme can also be utilized.

3.5 Multiple Access Interference

Multiple Access Interference (MAI) is a type of interference caused by multiple cellular users who are using the same frequency allocation at the same time. With CDMA systems, the same-frequency channel can be reused in the adjacent cell, as long as multiple-access interference is kept below a given threshold level necessary to meet the signal quality requirement. Multiple-access interference can present a significant problem if the power level of the desired signal is significantly lower (due to distance) than the power level of the interfering user. MAI comprises of two types of interference: intracell interference and intercell interference.

- (a) Intracell interference is defined as the interference caused by other users operating within the same cell.
- (b) Intercell interference is defined as the interference caused at the mobile user in a cell due to reuse of the same CDMA channel in the neighboring cells.

Most of Intercell interference occur from the first and second tiers of the surrounding cells of the serving cell. The interference from more distant cells suffers more propagation attenuation, and hence can be ignored. The signals causing intercell interference are received at different power levels, because they are power controlled relative to other cell sites. As a consequence, intercell interference depends on the propagation losses from a mobile user to two different cell sites. In general, the relative power from mobile users in other cells will be attenuated relative to the power from the intracell mobile users due to larger distance [9]. Let \dagger be the relative inter-cell interference factor, and is defined as the ratio of intercell interference to intracell interference, that is,

$$\dagger = \frac{I_{intercellular}}{I_{intracell}} \quad (3.1)$$

It is assumed here that the traffic loading in all cells is the same. The value of intercell interference factor \dagger ranges from 0.5 to 20, depending upon the number of system

parameters and environmental conditions. The total interference or MAI is the combination of intracell interference and intercell interference.

Thus the MAI is directly proportional to the channel loading or capacity, M/Q . Ultimately, the MAI on a cellular CDMA is more significant at the individual receiver. The signal-to-interference-plus-noise ratio (SINR) at the individual receiver is given by

$$SINR = \frac{E_b}{(N_0 + I_{MAI})} \quad (3.2)$$

$$SINR = \frac{E_b}{I_{MAI} \left(\frac{N_0}{I_{MAI}} + 1 \right)} \quad (3.3)$$

$$SINR = \frac{E_b}{(1 + \dagger) \left[\left(\frac{M}{Q} \right) E_b \right] \left(\frac{N_0}{I_{MAI}} + 1 \right)} \quad (3.4)$$

$$SINR = \frac{1}{(1 + \dagger) \left(\frac{M}{Q} \right) \left(\frac{N_0}{I_{MAI}} + 1 \right)} \quad (3.5)$$

Cellular CDMA systems are often interference limited; that is, the operating conditions are such that I_{MAI}/N_0 , typically 6 to 10 dB higher. The I_{MAI}/N_0 ratio depends upon the cell size. With large cells and battery-operated mobile phones, most of the transmit power is used to achieve the desired range. Thus large cells tend to be noise limited. Smaller cells tend to be interference limited and the interference level at the receiver is typically greater than the noise level of the receiver.

This expression shows the three system design factors that affect the SINR at the receiver, and limit spectral efficiency. The three factors are the intercell interference s , the channel loading M/Q , and the operating I_{MAI}/N_0 . The intercell interference depends on the environment as well as on the handover technique; channel loading is clearly a design parameter that needs to be maximized in a commercial cellular system; and, the third factor, I_{MAI}/N_0 , is related to cell size. There is a trade-off between these three system design parameters. For example, for a constant SINR, moving from a noise-limited system ($I = 0$ dB) to an interference-limited system ($I_{MAI}/N_0 = 10$ dB, say) increases the permissible channel loading or capacity. The channel loading must be significantly decreased to support a noise-limited system at the same SINR. Thus, large cells must have lighter load than small cells.

Similarly, for a constant SINR, increasing intercell interference significantly reduces the permissible channel loading. The methods of reducing the required SINR in CDMA systems are use of RAKE receivers and FEC coding. However, soft handoffs are the key design aspect to reducing margins and keeping intercell interference low. On the other hand, I_{MAI}/N_0 reducing the SINR required by the receiver can significantly improve the permissible channel loading.

3.6 Advantages of CDMA Techniques

The advantages of CDMA techniques are as follow:

- (a) Efficient practical utilization of fixed frequency spectrum.
- (b) Flexible allocation of resources.
- (c) Many users of CDMA use the same frequency, TDD or FDD may be used
- (d) Multipath fading may be substantially reduced because of large signal bandwidth
- (e) No absolute limit on the number of users, Easy addition of more users.
- (f) Impossible for hackers to decipher the code sent
- (g) Better signal quality
- (h) No sense of handoff when changing cells
- (i) The CDMA channel is nominally 1.23 MHz wide.
- (j) CDMA networks use a scheme called soft handoff, which minimizes signal breakup as a handset passes from one cell to another.
- (k) CDMA is compatible with other cellular technologies; this allows for nationwide roaming.
- (l) The combination of digital and spread-spectrum modes supports several times as many signals per unit bandwidth as analog modes.

3.7 Disadvantages of Using CDMA

The disadvantages of CDMA techniques are as follow:

- (a) As the number of users increases, the overall quality of service decreases
- (b) Self-jamming
- (c) Near- Far- problem arises

3.8 Limitations

The performance of CDMA technique is limited by various reasons. Therefore, the optimum performance considering this limitation and maximum research works try to get a better performance. The common limitations of this field are as follow:

3.8.1 Limitation of a Wireless Communication System with CDMA Technique

In this chapter, we address the issues related to the technical limitations of traditional CDMA technology. The discussions carried out here will pave the way for the definition and proposal of next generation CDMA technology, which should be built up based on a thorough understanding of the problems associated with traditional CDMA systems. The currently available CDMA technology was proposed basically for slow-speed voice-centric applications and thus bears many features pertaining to second generation mobile cellular systems, in particular the IS-95 standard. On the other hand, the birth of all CDMA-based 3G mobile cellular standards, such as WCDMA, cdma2000, and TD-SCDMA, was driven primarily by the competition between Japan and Korea for development of CDMA-based mobile cellular technologies, and thus sacrificing some great opportunities to bring sufficient technological innovations to the CDMA-based 3G mobile cellular standards.

3.8.2 Fading Limitation

In wireless communications, fading is deviation of the attenuation that a carrier-modulated telecommunication signal experiences over certain propagation media. The fading may vary with time, geographical position and/or radio frequency and is often modeled as a random process.

Fading channels a communication channel that experiences fading. In wireless systems, fading May either is due to multipath propagation, referred to as multipath induced fading or due to shadowing from obstacles affecting the wave propagation, sometimes referred to as shadow fading. Fading is two types. These are slow and fast fading, which are discussed here.

3.8.2.1 Slow versus Fast Fading

The terms slow and fast fading refer to the rate at which the magnitude and phase change imposed by the channel on the signal changes. The coherence time is a measure of the minimum time required for the magnitude change of the channel to become uncorrelated from its previous value.

(a) Slow fading arises when the coherence time of the channel is large relative to the delay constraint of the channel. In this regime, the amplitude and phase change imposed by the channel can be considered roughly constant over the period of use. Slow fading can be caused by events such as shadowing, where a large obstruction such as a hill or large building obscures the main signal path between the transmitter and the receiver. The amplitude change caused by shadowing is often modeled using a log-normal distribution with a standard deviation according to the log-distance path loss model.

(b) Fast fading occurs when the coherence time of the channel is small relative to the delay constraint of the channel. In this regime, the amplitude and phase change imposed by the channel varies considerably over the period of use.

Fading can be caused by natural weather disturbances, such as rainfall, snow, fog, hail and extremely cold air over a warm earth. Fading can also be created by manmade disturbances, such as irrigation, or from multiple transmission paths, irregular earth surfaces, and varying terrains.

3.9 Fading

Two types of Fading are discussed here. They are:

3.9.1 Frequency Selective Fading

Frequency-selective fading is caused by multi-path propagation of the channel due to the fact that the frequency response function of the channel exhibits uneven gains in different frequencies, hence the name 'frequency-selective fading'. Therefore, frequency-selective fading can be simply interpreted as uneven gains at different frequencies.

3.9.2 Time Selective Fading

Time-selective fading is caused by the Doppler Effect in the mobile communication channel, where terminals are in motion at a certain speed relative to the base station which is the receiver of the signals from the mobile terminals. Therefore, time-selective fading occurs due to the time-variant properties of a mobile channel. In this respect, we can also describe time-selective fading as the effect that uneven gains occur at different times.

3.9.3 Rician Fading

Rician fading is a stochastic model for radio propagation anomaly caused by partial cancellation of a radio signal by itself. The signal arrives at the receiver by several different paths (hence exhibiting multipath interference), and at least one of the paths is changing (lengthening or shortening). Rician fading occurs when one of the paths, typically a line of sight signal, is much stronger than the others. In Rician fading, the amplitude gain is characterized by a Rician distribution.

A Rician fading channel can be described by two parameters: K and Ω .

K = ratio between the power in the direct path and the power in the other, scattered, paths.

Ω = total power from both paths ($\Omega = \sigma^2 + 2\sigma^2$) acts as a scaling factor to the distribution.

Where, $\sigma^2 = \frac{\Omega}{2(1+K)}$

The resulting PDF then is,

$$f(x) = \frac{2(K+1)x}{\Omega} \exp\left(-K - \frac{(K+1)x^2}{\Omega}\right) I_0\left(2\sqrt{\frac{K(K+1)}{\Omega}}x\right) \quad (3.6)$$

Where I_0 is the 0th order modified Bessel functions of the first kind.

3.9.4 Rayleigh Fading

Rayleigh fading is the specialized model for stochastic fading when there is no line of sight signal, and is sometimes considered as a special case of the more generalized concept of Rician fading. In Rayleigh fading, the amplitude gain is characterized by a Rayleigh distribution. Rayleigh fading is a statistical model for the effect of a propagation environment on a radio signal, such as that used by wireless devices. Rayleigh fading models assume that the magnitude of a signal that has passed through

such a transmission medium (also called a communications channel) will vary randomly, or fade, according to a Rayleigh distribution. Rayleigh fading is viewed as a reasonable model for tropospheric and ionospheric signal propagation as well as the effect of heavily built-up urban environments on radio signals [15]. Rayleigh fading is most applicable when there is no dominant propagation along a line of sight between the transmitter and receiver. If there is a dominant line of sight, Rician fading may be more applicable.

Rayleigh fading is a reasonable model when there are many objects in the environment that scatter the radio signal before it arrives at the receiver. The central limit theorem holds that, if there is sufficiently much scatter, the channel impulse response will be well-modeled as a Gaussian process irrespective of the distribution of the individual components. If there is no dominant component to the scatter, then such a process will have zero mean and phase evenly distributed between 0 and 2π radians. The envelope of the channel response will therefore be Rayleigh distributed.

Calling this random variable R , it will have a probability density function [14]

$$f_R(r) = \frac{2r}{\Omega} e^{-r^2/\Omega} \quad (3.7)$$

3.10 Generating Rayleigh Fading

Rayleigh fading channel itself can be modeled by generating the real and imaginary parts of a complex number according to independent normal Gaussian variables. However, it is sometimes the case that it is simply the amplitude fluctuations that are of interest. There are two main approaches to this. In both cases, the aim is to produce a signal that has the Doppler power spectrum given above and the equivalent autocorrelation properties.

3.11 Delay Spread

In communications, the delay spread is a measure of the multipath richness of a channel. It measures the difference between the time of arrival of the first significant multipath component (typically the line-of-sight component) and the time of arrival of the last multipath component. It is mostly used in the characterization of wireless channels, but the same concept applies to any other multipath channel (e.g. multipath in optical fibers). The delay spread can be characterized through different metrics, although the most

common one is the root mean square (rms) delay spread. The importance of delay spread is how it affects the Inter Symbol Interference (ISI). If the symbol duration is big enough compared to the delay spread (typically 10 times as big would be good enough), one can expect an equivalent ISI-free channel.

3.12 Uses of CDMA and DS-CDMA

DS-CDMA (Direct-Sequence Code Division Multiple Access) is a multiple access scheme based on DSSS, by spreading the signals from/to different users with different codes. It is the most widely used type of CDMA. The uses of CDMA and DS-CDMA are as following:

- (a) One of the early applications for code division multiplexing is in GPS. This predates and is distinct from its use in mobile phones.
- (b) The Qualcomm standard IS-95, marketed as CDMA One.
- (c) The Qualcomm standard IS-2000, known as CDMA2000. This standard is used by several mobile phone companies, including the Global star satellite phone network.
- (d) The UMTS 3G mobile phone standard, which uses W-CDMA.
- (e) CDMA has been used in the Omni TRACS satellite system for transportation logistics.
- (f) Direct-sequence code-division multiple access (DS-CDMA) signals used in broadband communications over power lines.
- (g) DS-CDMA is used in mobile communication.
- (h) DS-CDMA used in Cordless phones operating in the 900 MHz, 2.4 GHz and 5.8 GHz bands.
- (i) DS-CDMA used in Automatic meter reading and Radio-controlled model automotive vehicles.

3.13 Benefits of DS-CDMA

The benefits of DS-CDMA are as following:

- (a) Resistive to intended or unintended jamming
- (b) Can be shared of a single channel among multiple users.
- (c) Reduced signal/background-noise level hampers interception.
- (d) Determination of relative timing between transmitter and receiver

Chapter 4

Performance Analysis of DS-CDMA

4.1 Performance Analysis of DS-CDMA

Any analysis of performance of a DS-CDMA system has to take into account the amount of MAI and its effects on the parameters that measure the performance, which includes the signal-to-interference-and-noise ratio (SINR) at the receiver and the related bit error probability on the information bit stream. Much more work on calculation of the user average bit error rate (BER) has done before on this area. The most widely used and popular approach is the Gaussian approximation (GA) [6] and its variants.

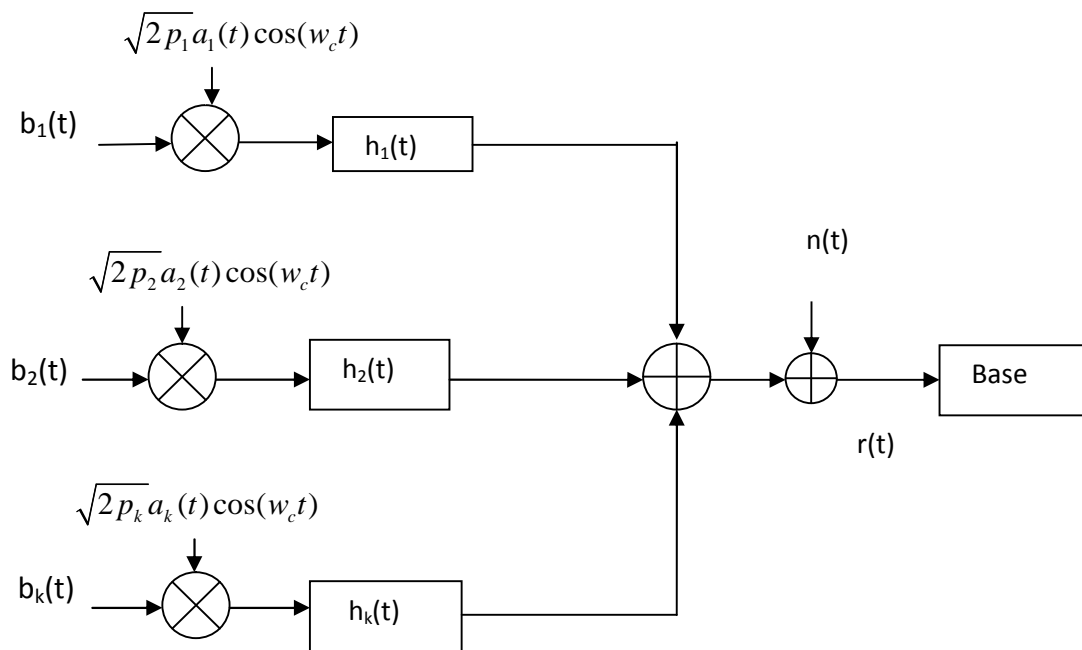

Figure 4.1. Reverse link DS-CDMA system model

The key parameter, bit error rate (BER) performance of an asynchronous DS-CDMA system over a frequency selective multipath Rayleigh fading channel with perfect power control is considered. The standard Gaussian approximation (SGA) is used to evaluate the BER performance for the DS-CDMA. This approximation is the most widely cited and most widely used [7], [5], [9-10] because of its simplicity. This BER performance is examined with varying numbers of multipath components, varying numbers of interfering cells, varying numbers of variance and various process gains, considering amplitude of the multipath component.

4.1.1 Transmitted Signal

Now we assume that the number of active users is K which transmits signals in DS-SS-SSMA system. The transmitting signal from each user is explained by [11]

$$s_k(t - \tau_k) = \sqrt{2P_k} b_k(t - \tau_k) a_k(t - \tau_k) \cos(\omega_c t + \theta_k) \quad (4.1.1)$$

Where, P_k is the power of the transmitted signal, ω_c is the carrier angular frequency, τ_k is the time delay and θ_k is the phase angle of the carrier signal, $b_k(t)$ is a binary data sequence and,

$$b_k(t) = \sum_{j=-\infty}^{\infty} b_j^k p_{T_b}(t - jT_b) \quad (4.1.2)$$

Where $p_{T_b} = 1$, for $0 \leq t < T_b$, and $p_{T_b} = 0$.

$a_k(t)$ is a pseudorandom sequence and,

$$a_k(t) = \sum_{i=-\infty}^{\infty} a_i^k \mathbb{E}(t - iT_c) \quad (4.1.3)$$

Where $\mathbb{E}(t)$ is a chip waveform with $0 \leq t < T_c$ and $\int_0^{T_c} \mathbb{E}^2(t) dt = T_c$. Where, T_c is the chip period, and r_i^k is the i^{th} chip value of the k^{th} user with the value either -1 or +1. Assume, N number of chips per bit where $N = T_b / T_c$ which is also known as the process gain for user k . Here considering the desired user is $k=0$ and others occur MAI.

4.1.2 Channel Model

In this system, we assume a frequency selective multipath Rayleigh fading channel $h_k(t)$, between the k^{th} user and the base station. The chip rate $1/T_c$ and the delay difference between any two different paths are higher than the channel coherence bandwidth and the chip duration T_c respectively. The impulse response of this channel is expressed by

$$h_k(t) = \sum_{l_k=1}^{L_k} \Gamma_{k,l_k} e^{jW_{k,l_k} t} e^{-j\omega_c(t - \tau_{k,l_k})} \quad (4.1.4)$$

Where W_{k,l_k} the phase of the multipath component is, τ_{k,l_k} is the path delay, L_k is the number of multipath components and Γ_{k,l_k} is the magnitude of the l^{th} multipath components with Rayleigh distribution.

4.1.3 Received Signal

The received signal for the base station is expressed as

$$r(t) = \sum_{k=0}^{K-1} \sum_{l_k=1}^{L_k} \sqrt{2P_k} \Gamma_{k,l_k} b_k(t - \tau_{k,l_k}) \times a_k(t - \tau_{k,l_k}) \cos(\check{S}_c t + W_{k,l_k}) + n(t) \quad (4.1.5)$$

Where $n(t)$ is Additive White Gaussian noise (AWGN) with a two-sided power density of $N_0/2$. The output is given by [17, 18]

$$\begin{aligned} Z_0 &= \int_0^{T_b} r(t) a_0(t - \tau_{0,0}) \cos(\check{S}_c t) dt \\ &= b_0 \Gamma_{0,0} \sqrt{\frac{P_0}{2}} T_b + \sum_{k=0}^{K-1} \sum_{l_k=1, l_k \neq 1}^{L_k} \Upsilon_{k,l_k} + \Upsilon' \end{aligned} \quad (4.1.6)$$

where b_0 is the transmitted bit, $\Gamma_{0,0}$ is the amplitude of the desired multipath component, P_0 is the transmitted power of the desired user, and Υ_{k,l_k} is a zero-mean Gaussian random variable with variance $\tau_{k,l_k}^2 = \frac{N_0 T_b}{4}$ and

$$\Upsilon' = \int_0^{T_b} n(t) a_0(t - \tau_{0,0}) \cos(\check{S}_c t) dt \quad (4.1.7)$$

We can re-write the equation (4.1.6) as

$$Z_0 = D_0 + \Upsilon + \Upsilon' \quad (4.1.8)$$

Where D_0 is the desired signal, Υ is the MAI and Υ' is the AWGN.

4.1.4 System Performance

To determine BER Gaussian Approximation can be used where Z_0 may be modeled as a Gaussian Random variable and this is called Standard Gaussian Approximation (SGA). In this system, to approximate MAI Central Limit Theorem (CLT) is used. Thus the receiver works as single user matched filter (correlation receiver) which detects the desired user signal. The SGA is more effective with the increasing number of interfering users.

The expression of BER can be given by [4]

$$BER_{L,r_{0,0}} = Q \left(\frac{\Gamma_{0,0}^2}{\sqrt{\frac{N_0}{2E_b} + \frac{2\tau^2}{3N} \left[\left(1 + \frac{M_c}{5}\right) LK - 1 \right]}} \right) \quad (4.1.9)$$

Where L is the number of multipath per user, M_c is the number of interfering cells, σ^2 is

the variance and $Q(n) = \frac{1}{\sqrt{2\pi}} \int_n^\infty e^{-\frac{u^2}{2}} du$

The average BER with averaging over the distribution of $\gamma_{0,0}$ and using the integral identity is expressed by [19]

$$BER_L = \frac{1}{2} - \frac{1}{2\sqrt{1 + \frac{N_0}{2E_b T^2} + \frac{2}{3N} \left[\left(1 + \frac{M_c}{5}\right) LK - 1 \right]}} \quad (4.1.10)$$

In this thesis, we use equation (4.1.9) and (4.1.10) to observe the BER performance of asynchronous DS-SS-CDMA system over a frequency selective multipath Rayleigh fading channel with perfect power control based on Standard Gaussian Approximation (SGA).

Chapter 5

Result and Discussions

5.1 Result and Discussions

Following the analytical approach in chapter 4 we evaluated the bit error rate (BER) performance of an asynchronous DS-CDMA system over a frequency selective multipath Rayleigh Fading channel with perfect power control. The standard Gaussian approximation (SGA) is used to evaluate the BER performance for the DS-CDMA with multipath and multiple access interference.

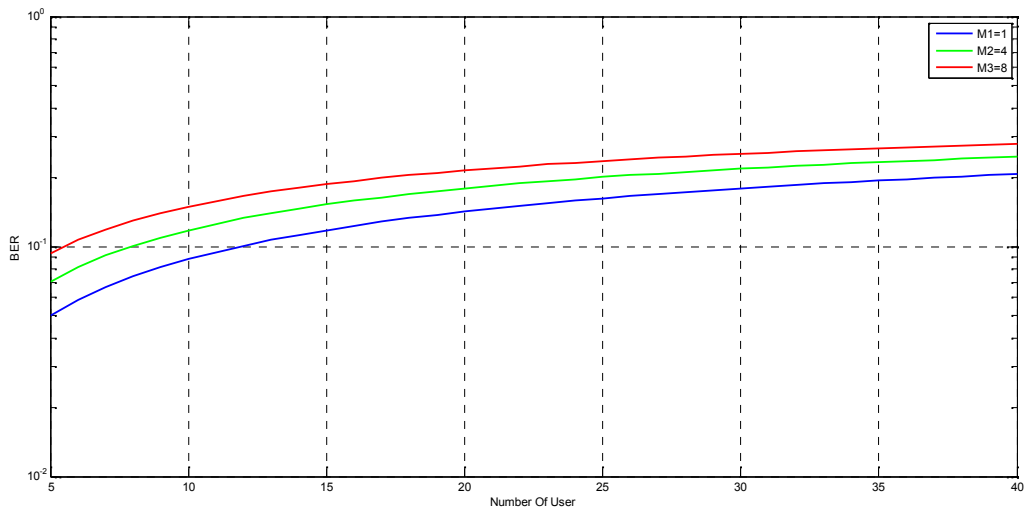

Figure 5.1. BER performance over a frequency selective multipath Rayleigh fading channel with perfect power control as a function of number of interfering cell with amplitude $a=1$.

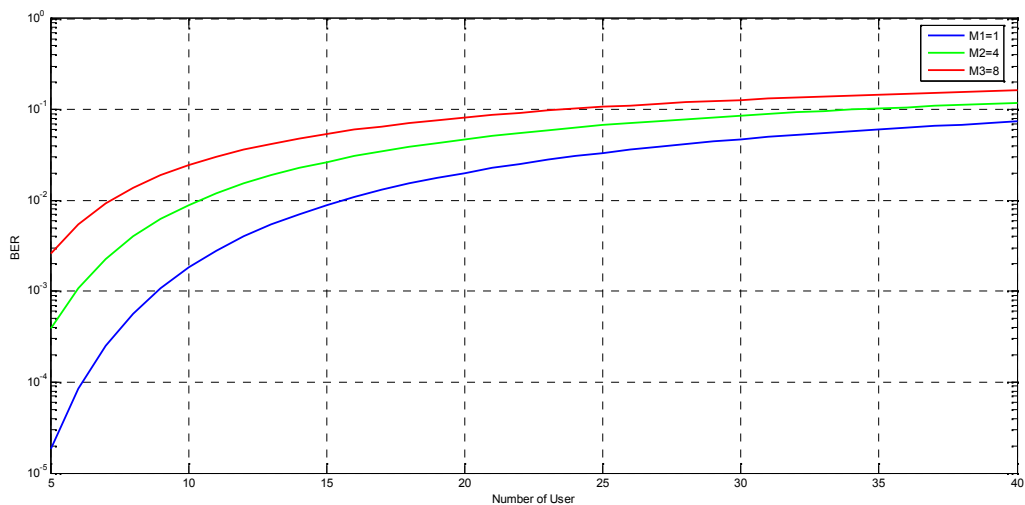

Figure 5.2. BER performance over a frequency selective multipath Rayleigh fading channel with perfect power control as a function of number of interfering cells with amplitude, $a=2$.

Plots of BER performance over a frequency selective multipath Rayleigh fading channel with perfect power control as a function of number of interfering cells is depicted in Figure 5.1 and Figure. 5.2 with $L=5$, $M=1, 4, 8$, the processing gain $N=84$ and $SNR=20$ with amplitude $a=1$ and $a=2$ respectively. It is noticed that, BER increases significantly with the increase of no of interfering cells M_c but decreases with the increases with signal amplitude.

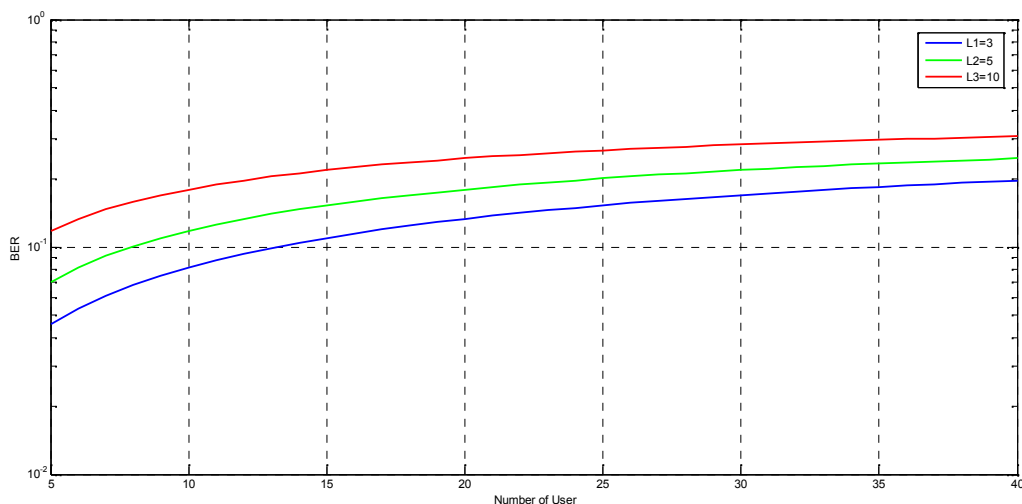

Figure 5.3. BER performance over a frequency selective multipath Rayleigh fading channel with perfect power control as a function of number of multipath components with signal amplitude $a=1$.

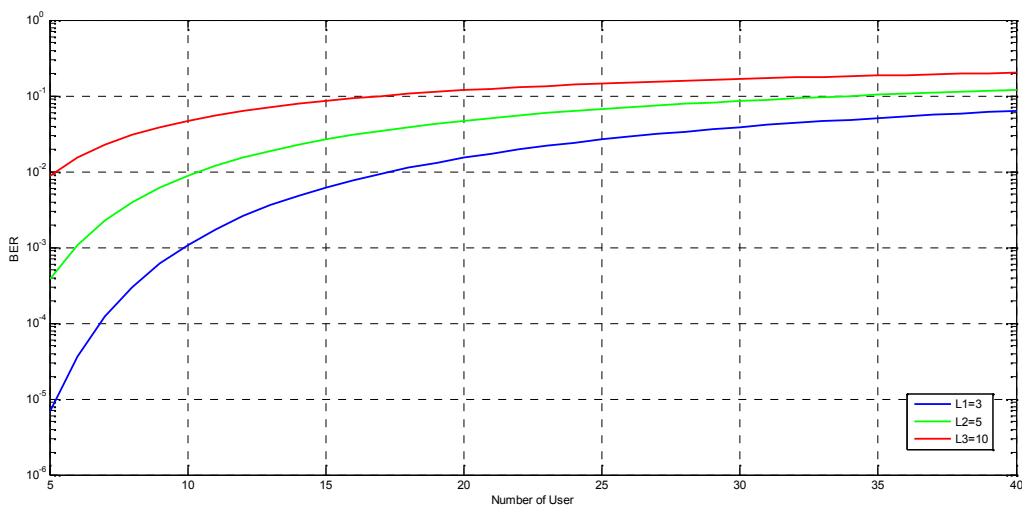

Figure 5.4. BER performance over a frequency selective multipath Rayleigh fading channel with perfect power control as a function of number of interfering cells with amplitude, $a=2$.

Plots of BER performance over a frequency selective multipath Rayleigh fading channel with perfect power control as a function of number of multipath components $L=3, 5, 10$, $M=4$, the processing gain $N=84$ and $SNR=20$ is shown in Figure. 5.3 and Figure. 5.4. It

is also noticed that, BER performance using SGA approximation has a significant impact on the variable multipath component L_k as well as signal amplitudes.

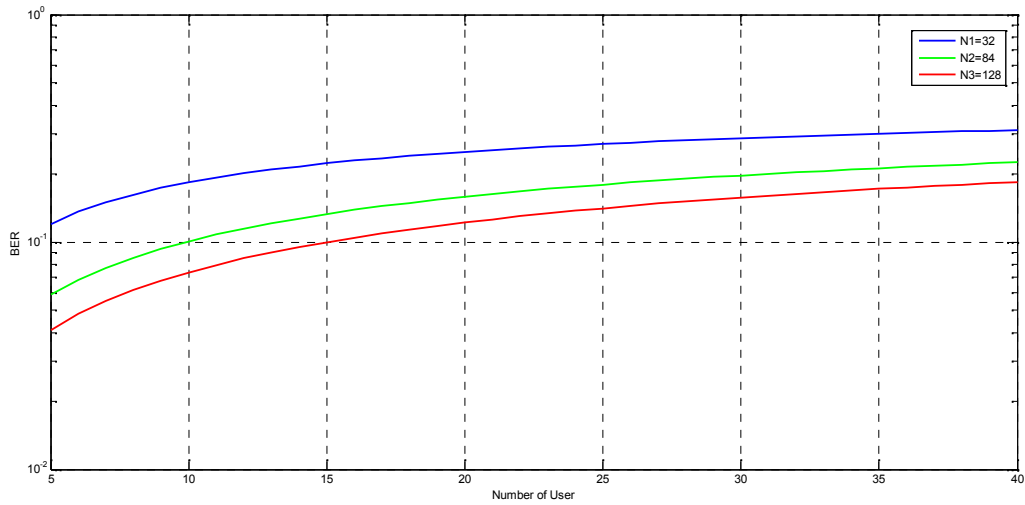

Figure 5.5. BER performance over a frequency selective multipath Rayleigh fading channel with perfect power control as a function of number of interfering cells with signal amplitude $a=1$.

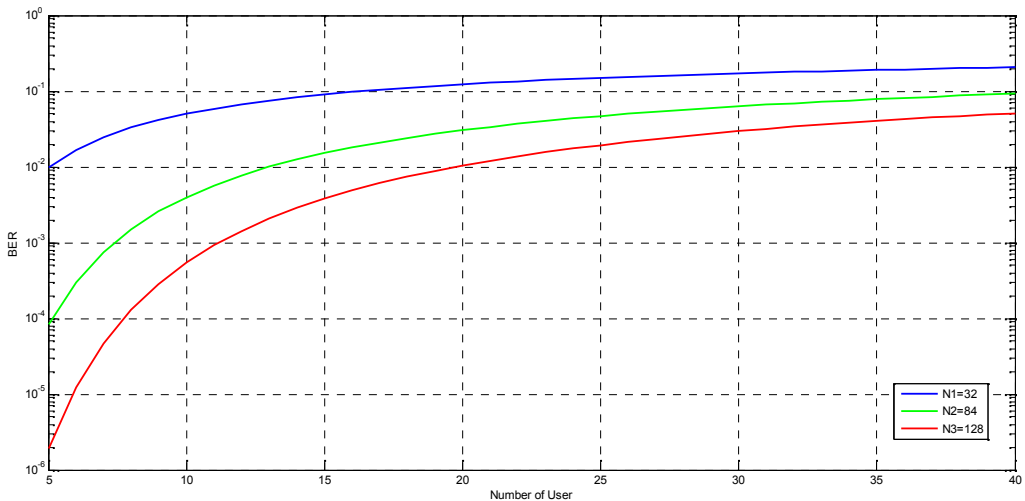

Figure 5.6. BER performance over a frequency selective multipath Rayleigh fading channel with perfect power control as a function of number of interfering cells with amplitude, $a=2$.

Plots of BER performance over a frequency selective multipath Rayleigh fading channel with perfect power control as a function of number of interfering cells with $L=5$, $M=4$, the processing gain $N=32$, 84 , 128 and $SNR=20$ with $a=1$ and $a=2$ respectively are shown in Figure 5.5 and Figure 5.6. The significant impact of the processing gain and signal amplitudes over BER is projected. BER has improved from 10^{-1} - $10^{-1.5}$ to 10^{-2} - 10^{-6} .

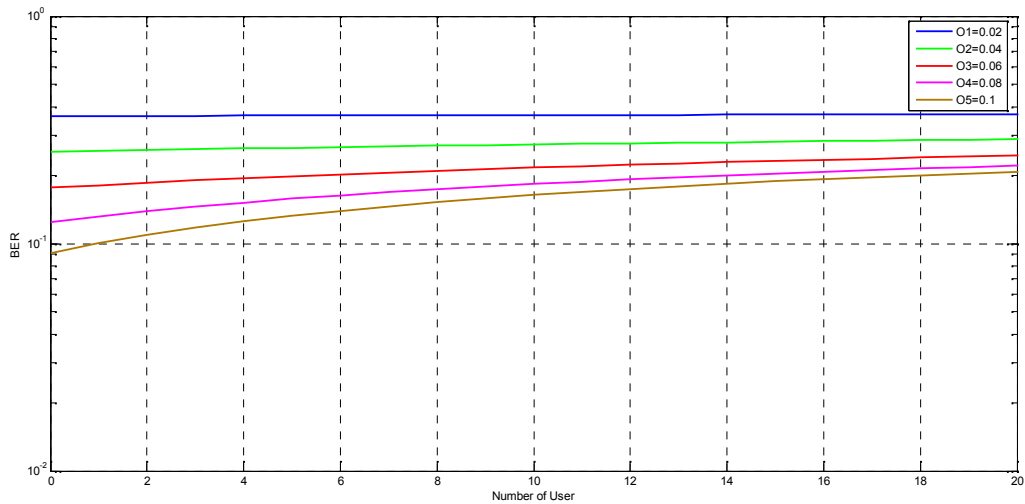

Figure 5.7. BER performance over a frequency selective multipath Rayleigh fading channel with perfect power control as a function of number of interfering cells for different fading variance.

BER performance over a frequency selective multipath Rayleigh fading channel with perfect power control as a function of number of interfering cells with $L=5$, $M=4$, the processing gain $N=84$ and $SNR=20$, for different fading variance are plotted in Figure 5.7. It is noticed that the fading variances has a significant impact on the BER performance over a frequency selective multipath Rayleigh fading channel.

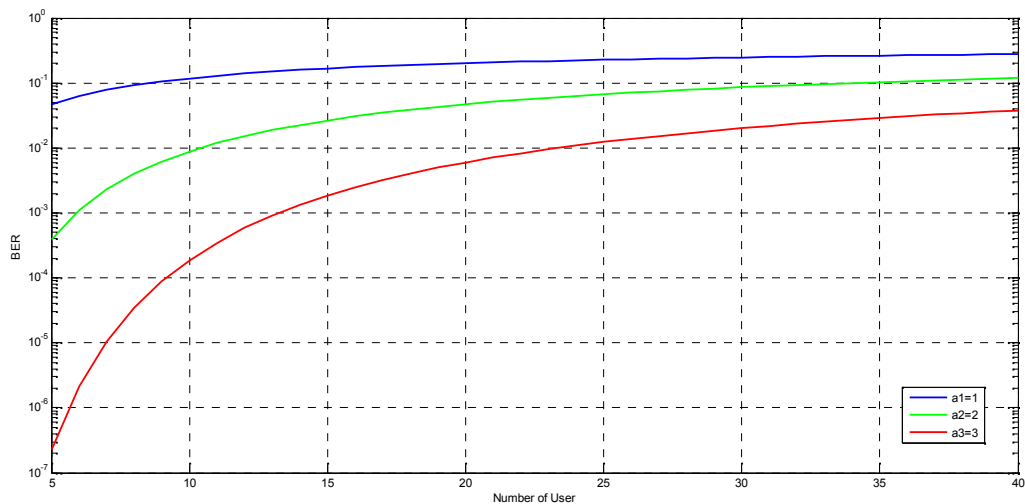

Figure 5.8. BER performance over a frequency selective multipath Rayleigh fading channel with perfect power control as a function of number of interfering cells with different signal amplitudes.

Figure 5.8 shows the BER performance over a frequency selective multipath Rayleigh fading channel with perfect power control as a function of number of interfering cells with $L=5$, $M=4$, the processing gain $N=84$, $SNR=20$ with signal amplitude, $a=1, 2, 3$

respectively. It is noticed that the BER performance has significantly increased with the increase of signal amplitudes.

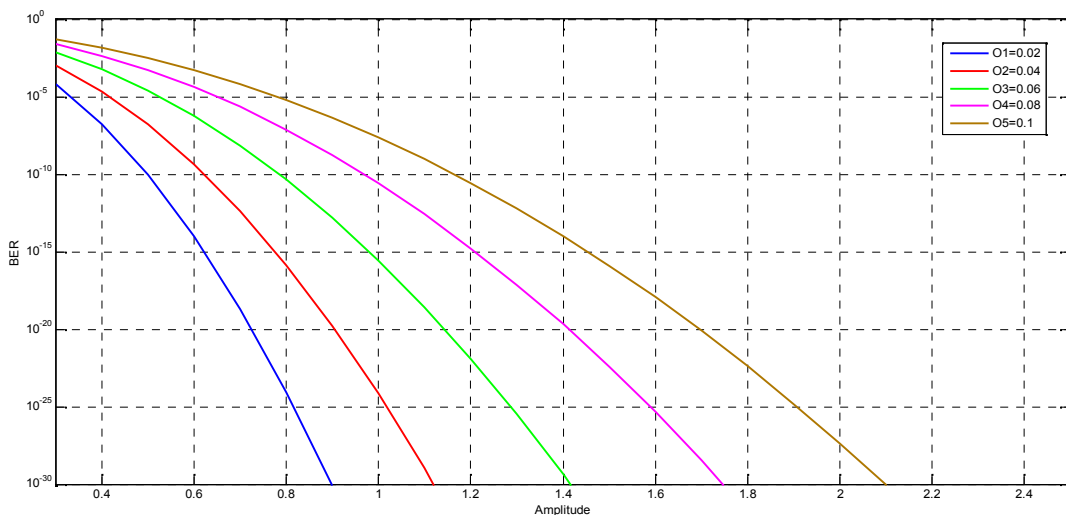

Figure 5.9. BER vs. signal amplitude over a frequency selective multipath Rayleigh fading channel with perfect power control considering fading variances as a parameter

Plots of BER vs. signal amplitude over a frequency selective multipath Rayleigh fading channel with perfect power control considering fading variances as a parameter are shown in Figure. 5.9. It is noticed that BER depends significantly over the channel fading variances as well as signal amplitudes. Plot shows that, BER performance has improved most significantly.

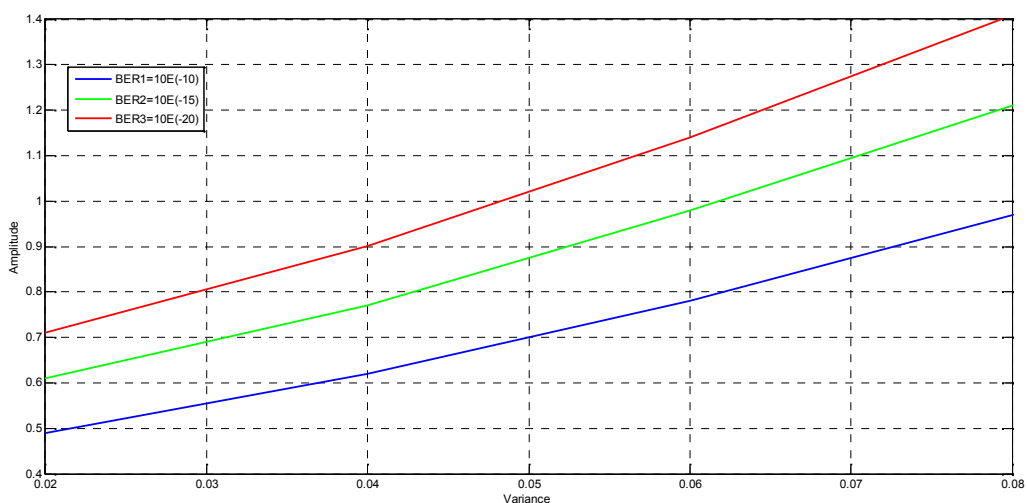

Figure 5.10. Variance vs. amplitude performance over a frequency selective multipath Rayleigh fading channel with perfect power control for constant BER.

Figure 5.10 depicted the channel fading variance vs. amplitude performance over a frequency selective multipath Rayleigh fading channel with perfect power control for

constant BER. It is noticed that, signal amplitude must be increased in proportion with the channel fading variances to maintain a constant improved BER.

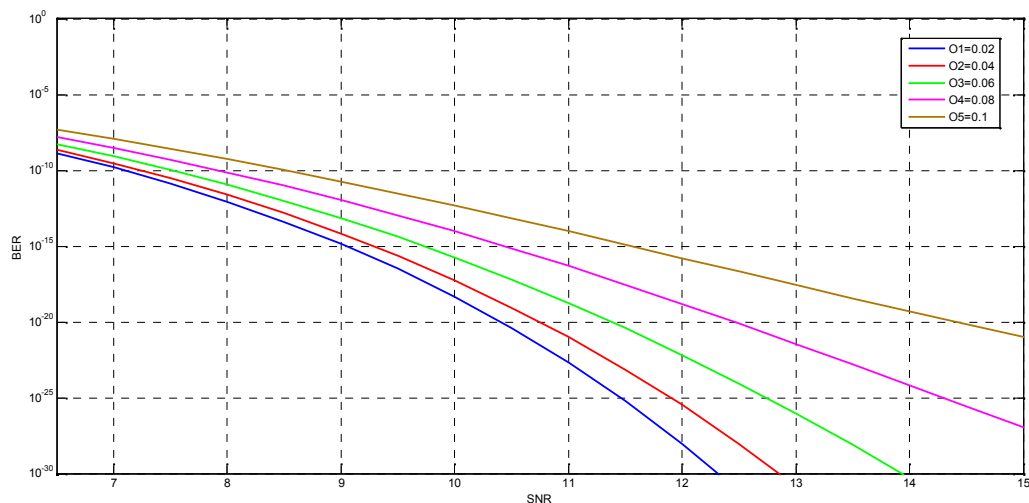

Figure 5.11. SNR vs. BER performance over a frequency selective multipath Rayleigh fading channel with perfect power control considering amplitude of multipath component for different fading variance.

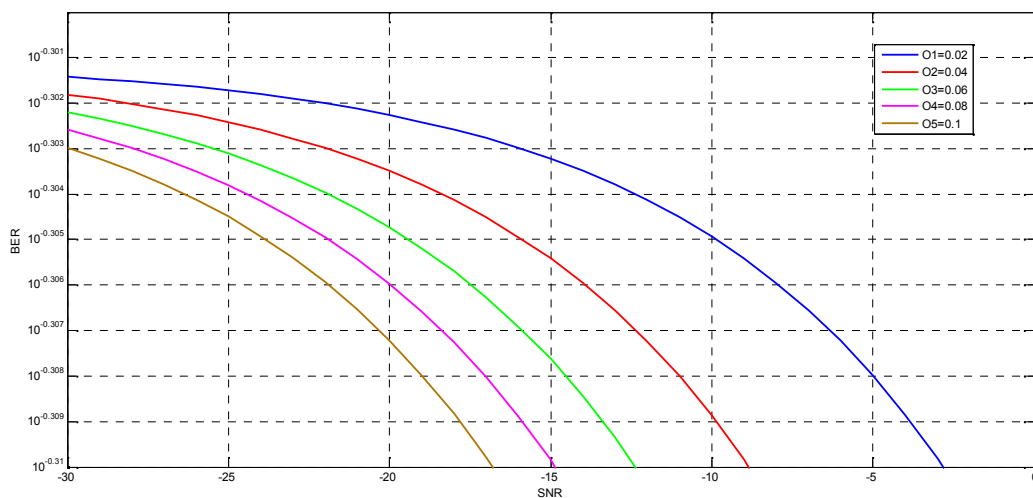

Figure 5.12. SNR vs. BER performance over a frequency selective multipath Rayleigh fading channel with perfect power control without considering amplitude of multipath component for different variance.

Plots of SNR vs. BER over a frequency selective multipath Rayleigh fading channel with perfect power control considering fading variances as a parameter are shown in Figure. 5.11 and in Figure 5.12 with and without considering signal amplitude respectively. It is noticed that BER depends significantly over the channel fading variances and signal amplitudes. Figure. 5.11 shows that, BER performance has improved most significantly similarly as in Figure 5.9.

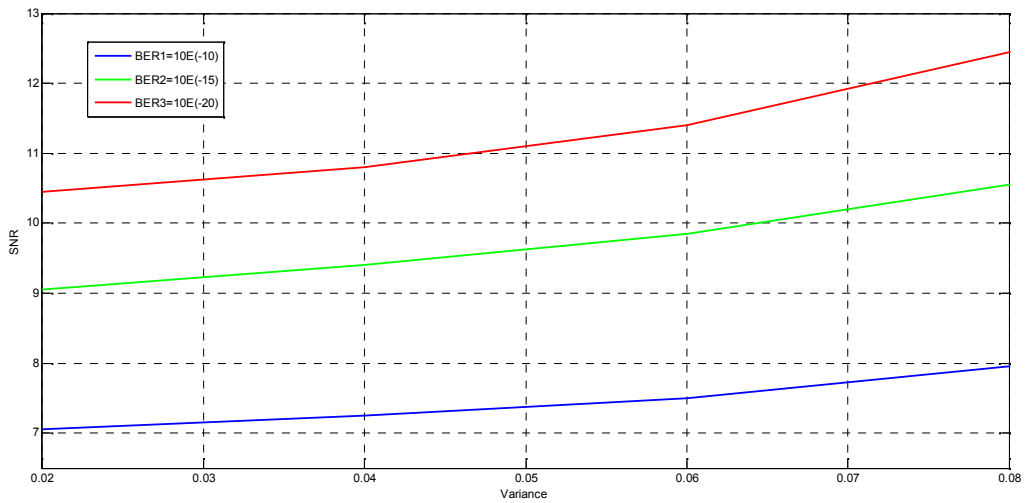

Figure 5.13. Variance vs. SNR performance over a frequency selective multipath Rayleigh fading channel with perfect power control considering amplitude of multipath component for constant BER.

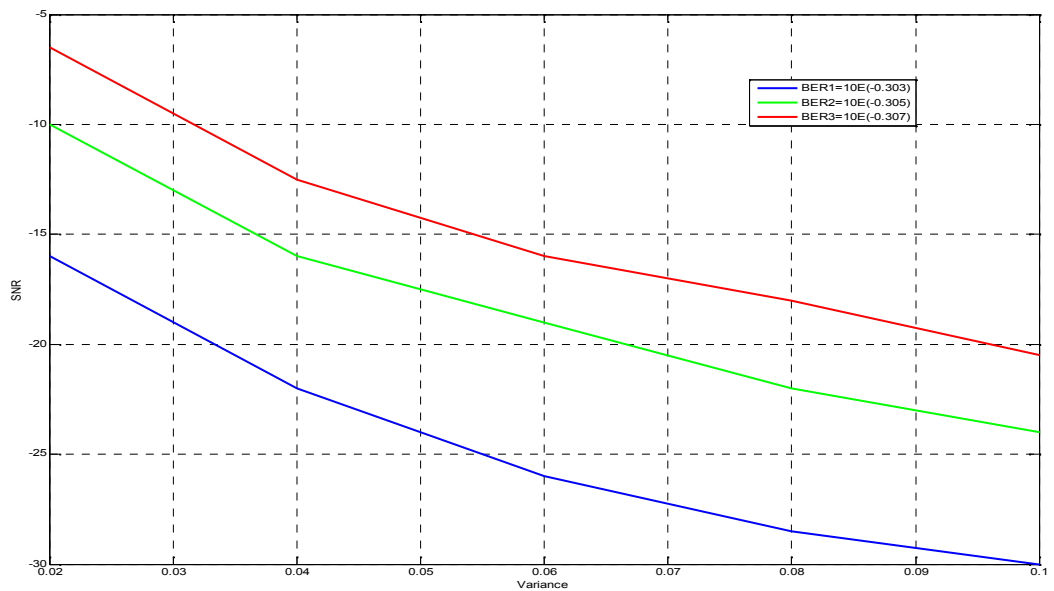

Figure 5.14. Variance vs. SNR performance over a frequency selective multipath Rayleigh fading channel with perfect power control without considering amplitude of multipath component for constant BER.

Plots of channel fading variance vs. SNR over a frequency selective multipath Rayleigh fading channel with perfect power control considering fading variances as a parameter are shown in Fig. 5.13 and in Fig 5.14 with and without considering signal amplitude respectively. It is noticed that SNR depends significantly over the channel fading variances and signal amplitudes. It is noticed that, approximately 10 dB power penalty is need to improve BER performances as shown in figures.

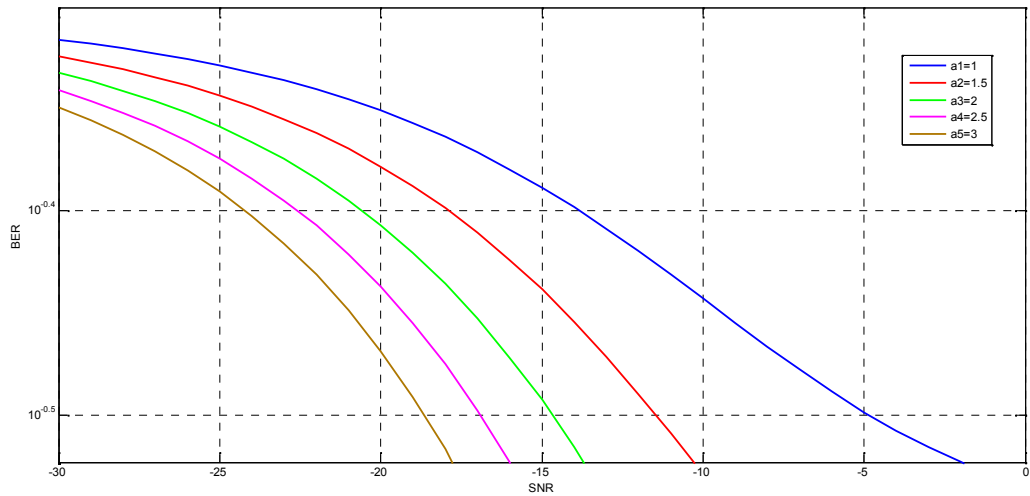

Figure 5.15. SNR vs. BER performance over a frequency selective multipath Rayleigh fading channel with perfect power control by varying amplitude of multipath component.

Plots of SNR vs. BER performance over a frequency selective multipath Rayleigh fading channel with perfect power control by varying amplitude of multipath component are shown in Figure 5.15. It is again noticed that, BER depends on signal amplitudes and SNR improvement.

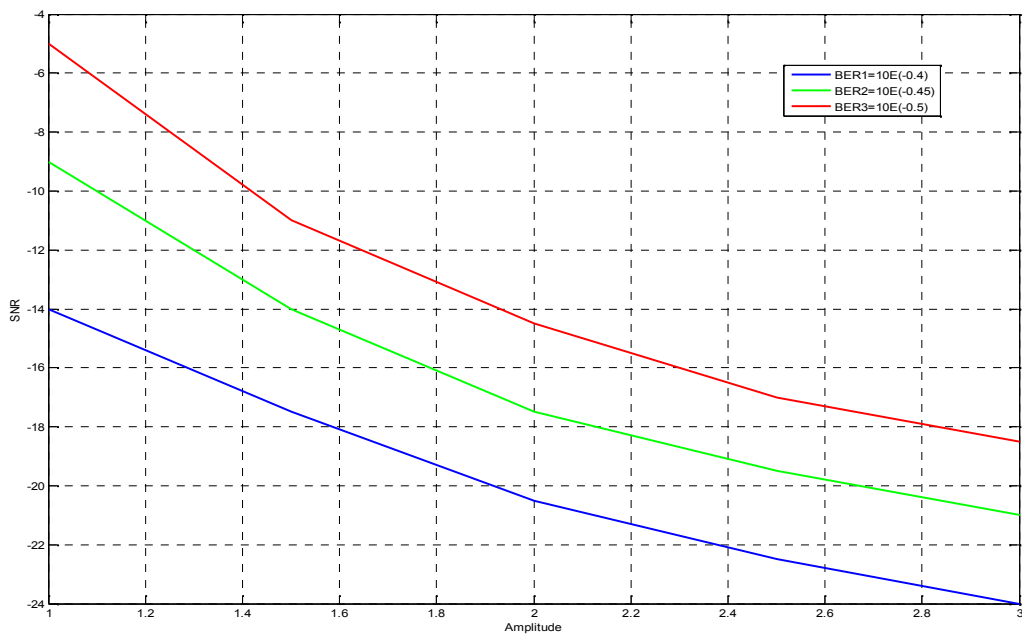

Figure 5.16. Amplitude vs. SNR performance over a frequency selective multipath Rayleigh fading channel with perfect power control and constant BER.

Plots of amplitude vs. SNR performance over a frequency selective multipath Rayleigh fading channel with perfect power control and constant BER are drawn in Figure. 5.16.

It is noticed that, approximately 10 dB power penalty is need to improve BER from $10^{-0.5}$ to $10^{-0.4}$.

5.2 Optimum System Parameter

Optimum system parameter for DS-CDMA system evaluated at BER 10^{-10} are shown in Table 5-1 and Table 5-2.

Table 5-1: Optimum System Parameter for Amplitude vs. BER

Serial Number	Parameter	Optimum Value Of Parameter	Remarks
1.	Signal To Noise Ratio (SNR)	20	
2.	Amplitude Of multipath component ()	0.5	
3.	Variance()	0.02	
4.	Process Gain (N)	84	
5.	Number Of Interfering Cells (M)	4	
6.	Number Of Multipaths Per User (L)	5	
7.	Number Of User (K)	40	

Table 5-2: Optimum System Parameter for SNR vs. BER

Serial Number	Parameter	Optimum Value Of Parameter	Remarks
1.	Signal To Noise Ratio (SNR)	7.09	
2.	Amplitude Of multipath component ()	2	
3.	Variance()	0.02	
4.	Process Gain (N)	84	
5.	Number Of Interfering Cells (M)	4	
6.	Number Of Multipaths Per User (L)	5	
7.	Number Of User (K)	40	

Chapter 6

Conclusion and Future Works

6.1 Conclusion

In this paper, we have briefly described the performance of an asynchronous DS-CDMA cellular system over a frequency selective multipath Rayleigh fading channel with perfect power control. We start with the background, history of DS-CDMA, techniques, types. We showed the theoretical analysis of BER, SNIR and evaluated BER for various system parameters. To evaluate the BER performance for the DS-CDMA system here we used the standard Gaussian approximation (SGA). Here we conclude that the BER performance is affected by the number of multipath components, the value of the process gain and number of interfering cells, variance and amplitude of the multipath component.

The CDMA history can be directly linked back to the 1940s when this form of transmission was first envisaged. As electronics technology improved, it started to be used for covert military transmissions in view of the facts that the transmissions look like noise, it is difficult to decipher without the knowledge of the right codes and furthermore it is difficult to jam. It is not our intention and is impossible either to provide an exhaustive literature search in the area through this paper. We did not include performance variations due to MAI where MAI causes degradation in bit error rate (BER) and system performance, multicarrier code division multiple access (MC-CDMA)-OFDM.

In this thesis, though we have discussed the limitations of DS-CDMA, only the limitation caused by MAI, fading due to multipath propagation are discussed. In this limited thesis work we did not investigate any solution to the limitation rather we recommend that the limitation due to MAI, various fading should be addressed for future work. Our recommendation for some future works on the reduction of limitations and better performance are listed in the following paragraph.

6.2 Future Works

Following are the areas of future study which can be considered for further research work.

- (a) 3G CDMA networks opened a door for possibilities in the CDMA technology field.
- (b) CDMA system can be tested with other modulation scheme.
- (c) We have considered only limitation due to multiple access interference on CDMA over Rayleigh fading. Other limitation can also be studied.
- (d) We discussed performance of DS-CDMA system over a frequency selective multipath Rayleigh fading channel with perfect power control; other effects can also be studied.
- (e) In this paper we have not presented any solution to the limitation. We have left it for the future studies.
- (f) We discuss only single carries DS-CDMA in this paper, Multicarrier – DS-CDMA with fading and limitations can be discussed for future work.
- (g) OFDM system can be tested with other modulation scheme.

References

- [1] Ageev, D. V. (1935). "Bases of the Theory of Linear Selection. Code Demultiplexing". Proceedings of the Leningrad Experimental Institute of Communication: 3–35.
- [2] R.Prasad, CDMA for Wireless Personal Communications, Artech House Publishers, 1996
- [3] Ojanper, Tero, Wideband CDMA for third generation mobile communications, Boston : Artech House, 1998.
- [4] T. S. Rappaport, Wireless Communication- Principles and Practice, Prentice-Hall, 1996.
- [5] Seedahmed S. Mahmud, Zahir M. Hussain and Peter O'Shea "BER performance of DS-SSMA system over a frequency selective multipath Rayleigh fading channel"
- [6] J. M. Holtzman, "A simple, accurate method to calculate spread-spectrum multiple-access error probabilities," IEEE Transactions on Communications, vol. 40, no. 3, pp. 461-464, March 1992.
- [7] N.Yee, J-P.Linnertz and G Fettweis, Multicarrier CDMA in indoor Wireless Radio Networks PROC of IEEE PIMRC '93, Yokohama, Japan sept.1993 pp0109-13
- [8] T. M. Lok, and J. S. Lehnert, "Error probabilities for generalized quadriphase DS-SSMA communication systems with random signature sequences," IEEE Transactions on Communications, vol. 44, no. 7, pp. 876-885, July 1996.
- [9] Performance analysis of a MC-OFDM DS-SSMA system over a faded channel, Dr. Satya Prasad Majumder, Jakia Sarwar, Tanziha Nujhat
- [10] Article: Multiple-access interference reduction for DS-SSMA systems with a novel class of polyphase sequences, Seong Ill Park, So Ryoung Park, Ickho Song, N. Suehiro, IEEE Transactions on Information Theory 08/2000.
- [11] J. S. Lehnert, and M. B. Pursley, "Error probabilities for binary direct-sequence spread-spectrum communications with random signature sequences," IEEE Transactions on Communications, vol.COM-35, no. 1, pp. 87-98, Jan. 1987.

- [12] Perfect power control in a multiservice CDMA cellular system, Ataman, S.; Ecole Superieure d'Electricite, Gif sur Yvette, France ; Wautier, A., Personal, Indoor and Mobile Radio Communications, 2002. The 13th IEEE International Symposium on (Volume: 3)
- [13] Convergence Technologies for 3G Networks .IP, UMTS, EGPRS and ATM (Jeffrey Bannister, Paul Mather and Sebastian Coopeat Orbitage Consultants).
- [14] John G. Proakis (1995). Digital Communications (3rd ed.). Singapore: McGraw–Hill Book Co. pp. 767–768. ISBN 0-07-113814-5.
- [15] William C. Jakes, Editor (February 1, 1975). Microwave Mobile Communications. New York: John Wiley & Sons Inc. ISBN 0-471-43720-4.
- [16] Universal frequency reuse: the CDMA advantage in capacity for digital cellular radio, 27-30 Mar 1991, 10.1109/PCCC.1991.113842, IEEE.
- [17] M. O. Sunay, and P. J. McLane, “Calculation error probabilities for DSCDMA systems: When not to use the Gaussian approximation,” IEEE Global Telecommunications Conference, Globecom’96, vol. 3, pp. 1744-1749, Nov. 1996.
- [18] J. Mar, and H. Y. Chen, “Performance analysis of cellular CDMA networks over frequency-selective fading channel,” IEEE Transactions on Vehicular Technology, vol. 47, no. 4, pp. 1234 -1244, Nov. 1998.
- [19] J. Cheng, and N. C. Beaulieu, “Accurate DS-CDMA bit-error probability calculation in Rayleigh fading,” IEEE on Wireless Communications, vol. 1, no. 1, pp. 3-15, Jan. 2002.
- [20] Wikipedia
- [21] www.cdg.org
- [22] Method and apparatus for controlling transmission power in a CDMA cellular mobile telephone system, Klein S. Gilhousen, Roberto Padovani, Lindsay A. Weaver, Jr., US5485486 A, US 08/217,003, Jan 16, 1996