

# UNDERSTANDING THE BEHAVIOUR OF LAUNCHING APRONS AROUND ABUTMENT: AN EXPERIMENTAL STUDY

K. M. Salzar Hossain<sup>1\*</sup> and M. Monowar Hossain<sup>2</sup>

<sup>1\*</sup>Military Institute of Science and Technology, Mirpur, Dhaka, Bangladesh

<sup>2</sup>Institute of Water Modeling (IWM), Dhaka

\*Corresponding author's email: salzarh@gmail.com

## ABSTRACT

This study aims to investigate the behaviour of a launching apron in a straight sand bed laboratory channel. The apron was made under clear-water condition and channel bed formed ripples during test runs. The hydraulic parameters have been set so that the flow is close to the critical condition of sediment transport. Three vertical-wall and three sloping-wall abutments have been considered for this test. Around these structures, scour depth, scour contour and velocity distribution have been observed. Results have been compared with some existing prediction methods and data. It was found that in the case of vertical-wall structures, results are comparable with existing prediction methods. However, in case of sloping-wall structures, the existing prediction methods do not produce so close agreement. Results show that when apron material has been laid around a structure, the apron behaves like a submerged extension of the original structure. The effect of the submerged extension has been found to be quite significant in scour formation and in vertical velocity distribution. The study shows that the launching apron protects the structure by forming a protective layer on the sloping face and forcing the scour hole to be formed away from the structure.

**Key Words:** Launching apron, vertical-wall Abutment, sloping-wall Abutment, scour formation, velocity distribution, Abutment.

## 1.0 INTRODUCTION

Usually hydraulic structures are protected against scour by placing launching aprons. Vertical-wall structures that are constructed up to a level below the maximum predicted scour depth, normally receive protection with the help of launching aprons. However, undermining effect is still believed to be the mostly observed risk factors against existence of hydraulic structures (Barkdoll et al. 2007, Novak et al, 2007). Basically, four methods are widely practised to prevent undermining. First is to excavate and continue the slope revetment down to an in-erodible material or to below the expected scour level. Second is to drive a 'cut-off wall' of sheet piling from the toe of the revetment

down to an in-erodible material or to below the expected scour level. Third is to lay a flexible 'launching apron' horizontally on the bed at the foot of the revetment, so that when scour occurs the materials will settle and cover the scour hole on a natural slope. Fourth is to pave the entire bed across the bridge waterway opening (Neill, 1975). In Indian subcontinent, use of launching apron is very popular for protection of structures from failures. Before placing launching apron, the maximum scour depth is predicted using existing formulae. But after placement of launching apron, the bed geometry gets modified and the existing formulae might not be suitable for correct prediction of scour depth around structures. When a structure is without apron, the scour process begins from

places adjacent to the structures. On the other hand, when apron material is provided, the scour process is initiated from the place, where apron material is extended.

The methods used in practice for calculating and laying apron materials are more than half-a-century old. No specific study has been conducted in recent years. Therefore, the effectiveness of those methods should be studied.

When riverbed is sandy, launching apron is the most economical method of protecting structures constructed on riverbanks. However, while designing launching apron, information regarding scour is to be known first. Therefore, scour study cannot be separated from apron study.

Spring's (1903) launching apron design shows that scour prediction and its protection study are more than hundred years old. Bridge scour has been a subject of interest and importance from the time of the earliest civilizations. The Iowa Institute of Hydraulic Research, the Colorado University, Central Water and Power Station, India are some of the organizations that have conducted investigations. Summary of investigations are available elsewhere (Breusers and Raudkivi 1991, Coleman 2000, Gill 1972, Inglis 1949, Gales 1938, Joglekar 1971, Melville 1992, and Neill 1975).

Barkdoll et al. (2007) studied the use of geo-bag as apron material and concluded that such bags could be effective in preventing scour formation at the toe of abutment. However, formation of scour hole downstream of abutment seems unavoidable. Oberhagemann et al. (2008) found that the commonly used falling aprons provide a useful tool if carefully applied to respond to immediate erosive attack, but do not provide long-term protection. However, geo-bags tend to show a better performance than cubical concrete blocks.

In a riverine country like Bangladesh, water scientists have been facing so many challenges in fixing the launching aprons near the piers and abutments. Moreover, the developed theories may not be very effective for applying to the mighty rivers of Bangladesh. Therefore more researches need to be carried out to study the behaviour of

in Bangladeshi rivers. Several researchers have conducted many studies considering the effectiveness of apron materials, design of aprons, characteristics of the launching apron, application of theories in calculating apron materials. A few of them have considered behaviour of aprons (Barkdoll et al. 2007, Breusers and Raudkivi 1991, Oberhagemann et al. 2008). However, an in-depth study of understanding the behaviour of launching apron for Bangladeshi river has not been conducted yet. Therefore, the objectives of this research are (i) to examine the variation of scour for structures with and without apron and (ii) to study the effect of different launching apron geometry on the protection of structures.

## 2.0 METHODS AND EXPERIMENTAL SETUP

2.1 The experiment can be divided into two phases. The first phase is on scour study and the second phase is on apron study.

During the scour study six structures, three vertical and three sloping abutments, have been considered. The scour depths, scour pattern, location of maximum scour depth, etc. have been observed. Results found have been compared with other investigators' data and existing designs to look for the consistency of experimental data. All the structures have been placed in the middle of the channel longitudinally so that, the flow can be developed and at the same time backwater effect has reduced.

During the apron study, one vertical structure has been selected and apron has been laid around this structure in six different geometries. Apron design has been based on Rao's method (1941). Deflection and concentration of velocity due to the presence of apron, launching of apron material, locations of maximum scour depths for different apron geometry, behaviour of apron material in sudden and regular flow, etc. have been observed. Apron behaviour has been also recorded with video camera. Besides, many still photographs have also been taken for better visual records. Results found here are compared with those of without apron cases to look for variations (Fig. 1). For each test, the channel bed has been prepared afresh. Each test has been run for 7 hours and 30 minutes.

While designing apron, scour depth found during first phase of study has been used. As per design, outer edge height of apron material should

have been 8.3 cm. Since this height becomes higher than the water level, the height of apron has been kept at 4.5 cm.

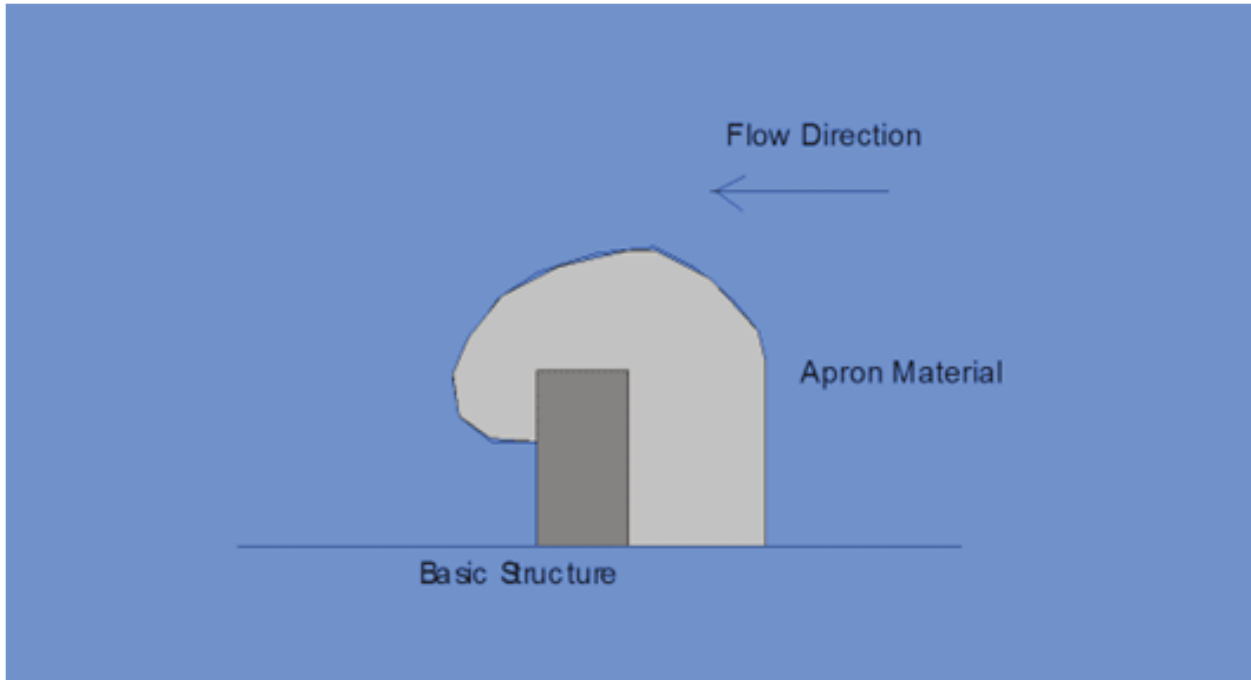

**Fig 1.** Basic Structure, Apron set up and Flow direction

### 2.2 Laboratory Channel

A 5m long and 1m wide straight channel has been set up with flow measuring facility (Fig. 2).

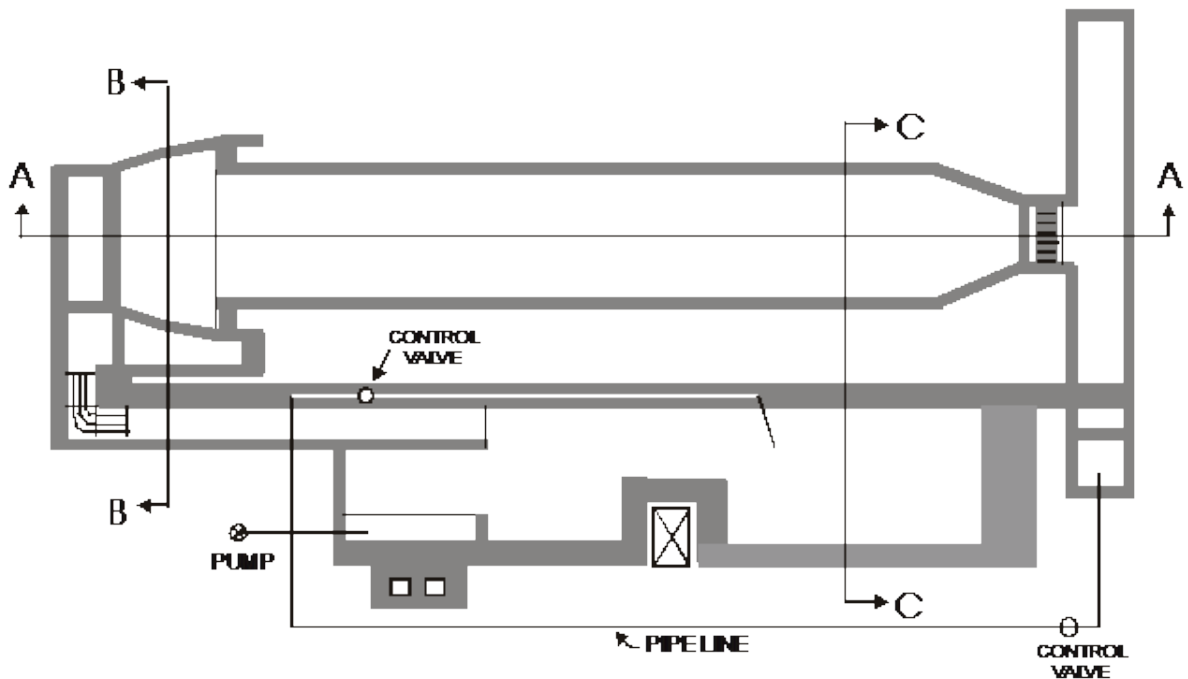

**Fig 2.** Channel and Control Arrangements

### 2.3 Hydraulic Parameters

Table 1 represents the summary of test hydraulic parameters of the study.

**Table 1** Summary of Test Hydraulic Parameters

SUMMARY OF TEST HYDRAULIC PARAMETERS											
B (m)	h (cm)	A (m <sup>2</sup> )	Q (l/s)	U (m/s)	D <sub>50</sub> (mm)	n	S	U <sup>*</sup> (m/s)	U <sub>τc</sub> (m/s)	U <sup>*</sup> /U <sub>τc</sub>	τ <sub>s</sub> /τ <sub>τc</sub>
2	5	0.1	30	0.3	0.28	0.012122082	0.00072	0.0188	0.016	1.196	1.430
2	8	0.2	30	0.188	0.28	0.012122082	0.00015	0.0108	0.016	0.691	0.478
2	10	0.2	30	0.15	0.28	0.012122082	0.00007	0.0084	0.016	0.533	0.284
2	12	0.2	30	0.125	0.28	0.012122082	0.00004	0.0068	0.016	0.431	0.185
2	15	0.3	30	0.1	0.28	0.012122082	0.00002	0.0052	0.016	0.332	0.110
2	5	0.1	40	0.4	0.28	0.012122082	0.00128	0.025	0.016	1.594	2.542
2	8	0.2	40	0.25	0.28	0.012122082	0.00027	0.0145	0.016	0.921	0.849
2	10	0.2	40	0.2	0.28	0.012122082	0.00013	0.0111	0.016	0.710	0.504
2	12	0.2	40	0.167	0.28	0.012122082	0.00007	0.009	0.016	0.574	0.330
2	15	0.3	40	0.133	0.28	0.012122082	0.00003	0.0069	0.016	0.443	0.196
2	5	0.1	50	0.5	0.28	0.012122082	0.00199	0.0313	0.016	1.993	3.972
2	8	0.2	50	0.313	0.28	0.012122082	0.00042	0.0181	0.016	1.152	1.327
2	10	0.2	50	0.25	0.28	0.012122082	0.00020	0.0139	0.016	0.888	0.788
2	12	0.2	50	0.208	0.28	0.012122082	0.00011	0.0113	0.016	0.718	0.515
2	15	0.3	50	0.167	0.28	0.012122082	0.00005	0.0087	0.016	0.553	0.306

### 2.4 Bed Material

Grain size distribution for bed materials is shown in Fig. 3. Bed material used allowed ripple formation so that live bed conditions prevail. Bed condition is shown in Fig. 7.

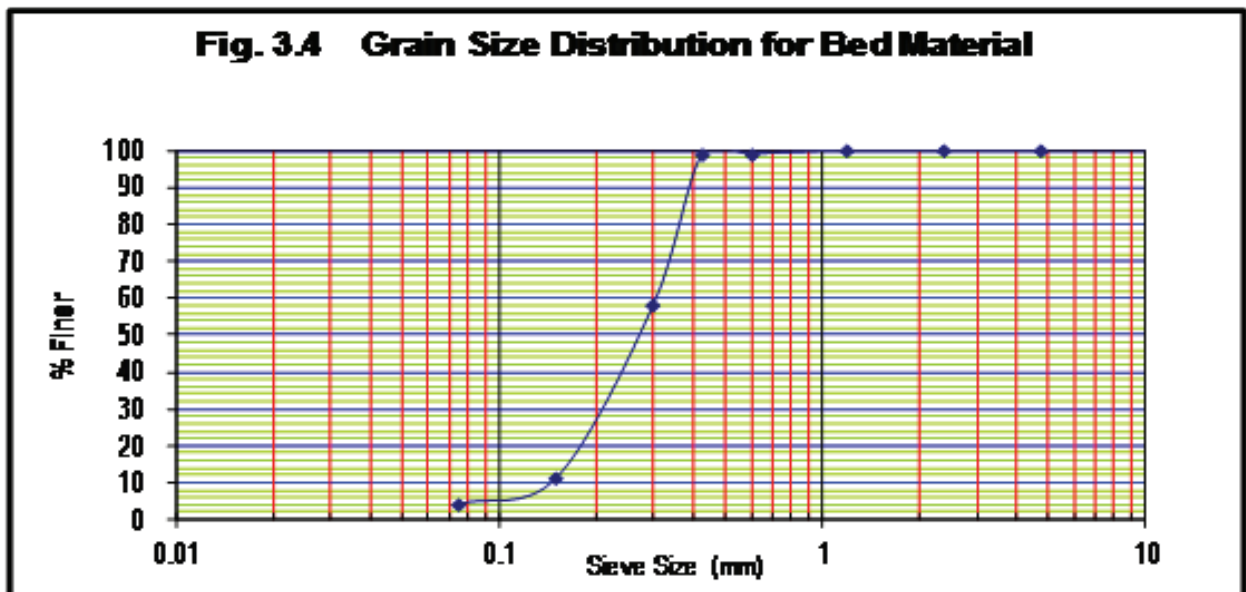

**Fig 3.** Grain Size Distribution for Bed Materials

### 2.5 Velocity Meter

Velocity meter has a probe that is required to be inserted in liquid whose velocity is to be measured. The probe has 4 sensing points. Because of the variation of magnetic field induced by the flow field voltage is produced. The sensing points measure these voltages. From these voltage inputs, outputs of velocities in X and Y direction have been collected as per the orientation of the velocity probe. The readings are displayed in the display

window of the meter. The meter could also be attached with a computer to record continuous data. It has been used to measure velocities around experimental structures.

### 2.6 Structures Used

Both vertical and sloping structures have been used for the experiment. The specifications of structures are given in Fig. 4, 5 and 6.

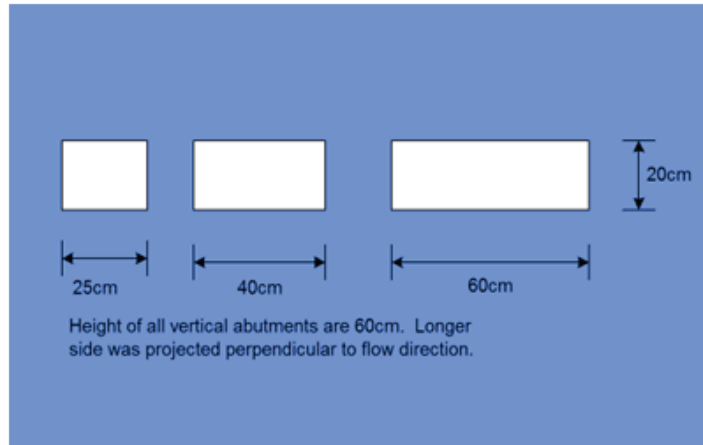

Fig 4. Vertical Structure Specifications

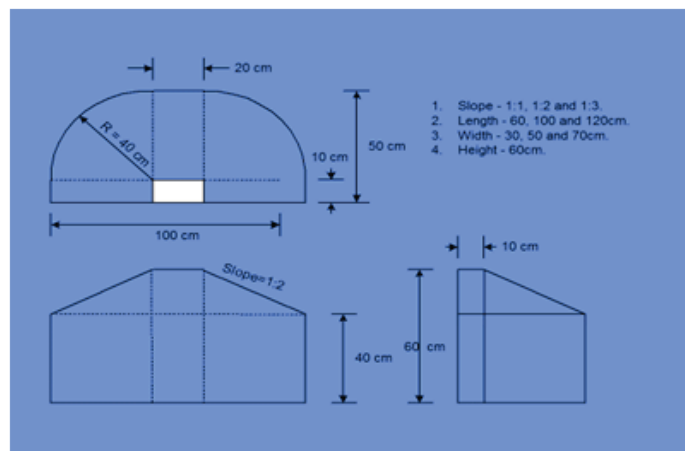

Fig 5. Sloping Structure Specifications

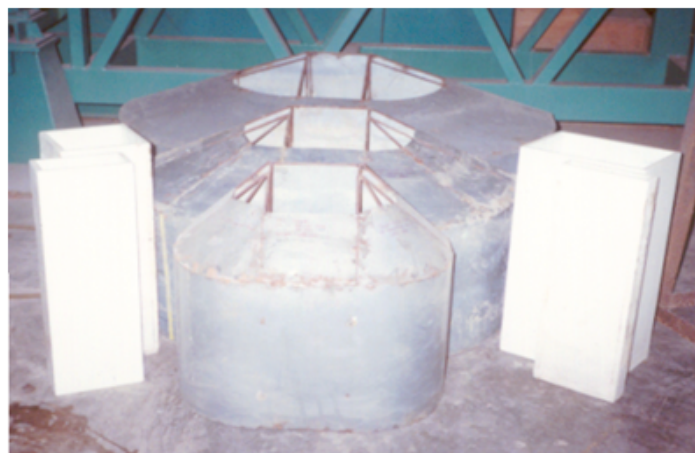

Fig 6. Abutments used for the Experiments



### 3.0 RESULTS

Results of the study are presented in this section.

#### 3.1 Ripple Height and Scour Measurement

Ripple height and scour measurements are fully manual. A wooden bridge has been placed on the laboratory channel. On this bridge a sliding platform has also been placed. On this platform, a long needle with a Vernier scale has been mounted in such a way that the needle with scale can move up and down with the help of a screw. The Vernier scale moves along a fixed main scale (Fig.7).



**Fig 7.** Ripple formation and Ripple Height Measurement

For ripple height measurement, a grid system has been used. But for scour measurement, same grid system cannot be used. Because, where the scour slope is steeper, closer data are required to be taken. However, the recorded data have been converted to grid data with the help of another software named "Winsurf".

In case of scour measurement, longitudinal and lateral scour depth profiles have been taken where the maximum scour depth has been produced. Scours around different structures are shown in following figures (Fig. 8, 9, 10, and 11).



**Fig 8.** Local Scour around a Vertical Abutment

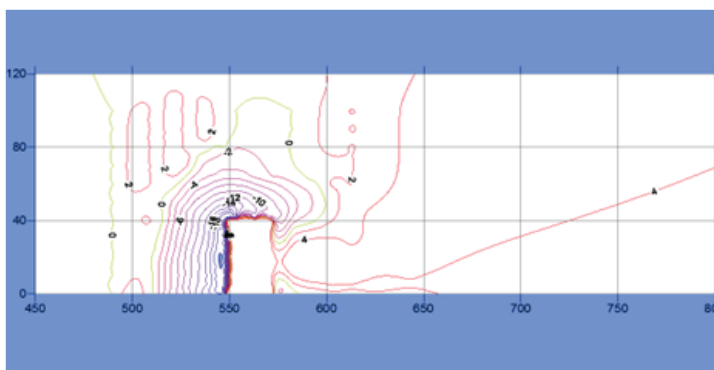

**Fig 9.** Contour Map of Scour Height for a Vertical Abutment



**Fig 10.** Local Scour around a Sloping Abutment

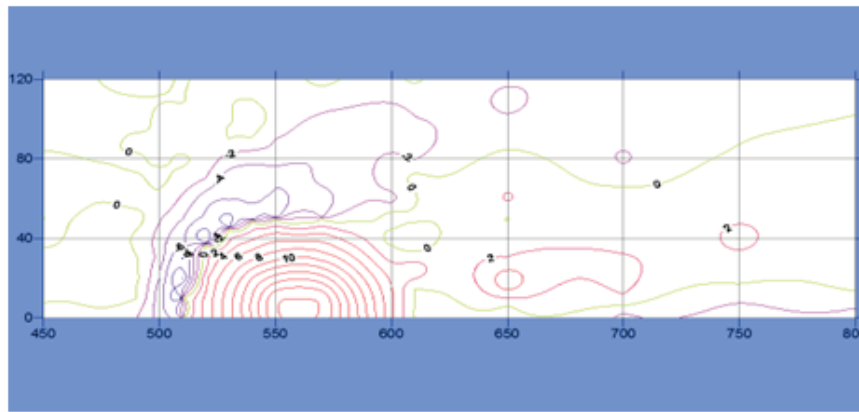
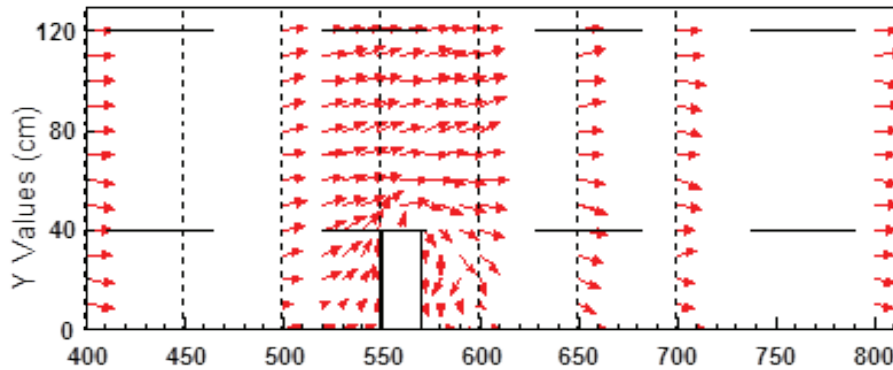

**Fig 11.** Contour Map of Scour Height for a Sloping Abutment

**3.2 Velocity Measurement**

For the present investigation, velocity has been measured with the help of computer. The name of software used is “Labview”. The flow field is divided

into a grid system and at each grid intersection point the velocity has been measured for 50 – 60 iterations. Finally, the average of these iterations are used as the velocity of that point (Fig. 12a and b).



(a)

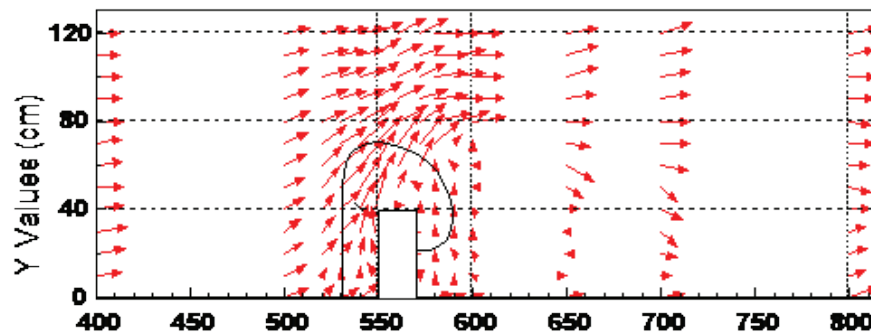

**X Values (cm)**

(b)

**Fig 12.** Velocity Distribution around the Abutment, a. without protection materials, b. with protection materials(b)

**3.3 Shape Factor**

While comparing scour depth with other data and design curves, it has been found that data for vertical abutments are consistent with other data

and design curves. Little variation observed may be because equilibrium stage has not been reached. Comparison results are shown in following figures (Fig. 13, 14, 15 and 16).

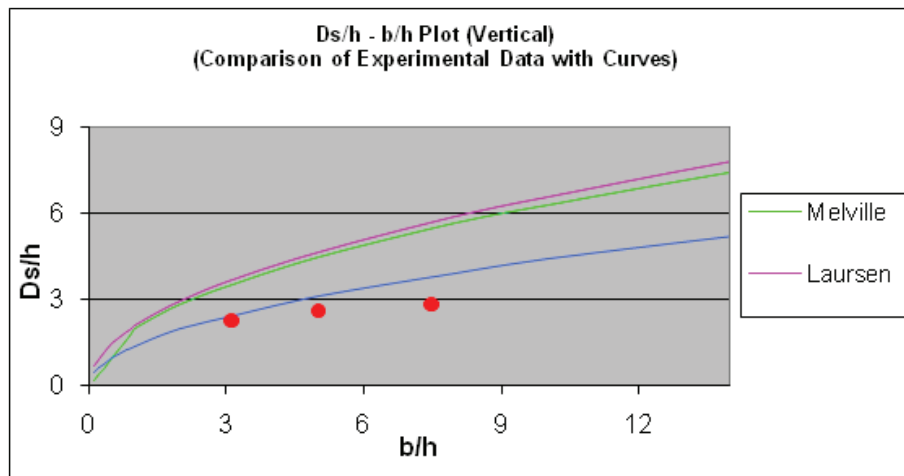

**Fig 13.** Comparison of experimental data with curves (Vertical)

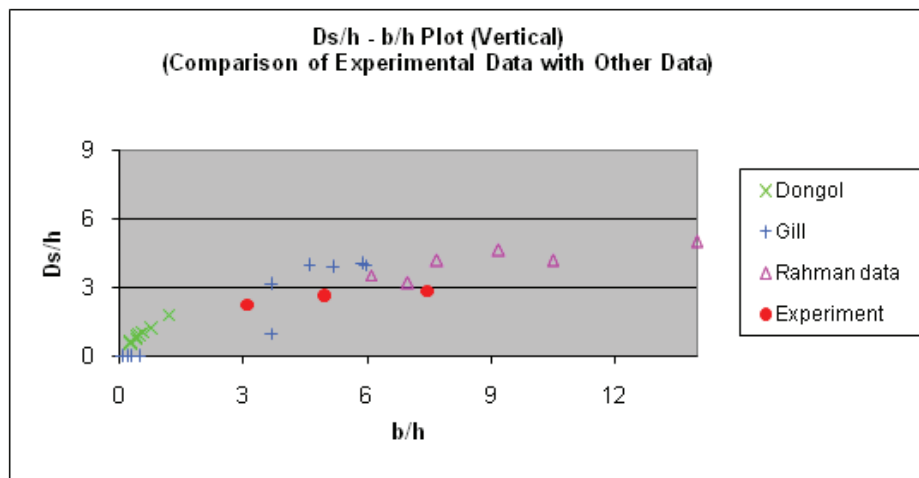

**Fig 14.** Comparison of experimental data with other data (Vertical)

For the cases of sloping abutments, the experimental data have not been found to be consistent with other data and design curves. Though data were not available for milder

slopes, design curve was available. In analysing the reason for wide variation between the experimental data and other data or design curves, the question of shape factor comes in.

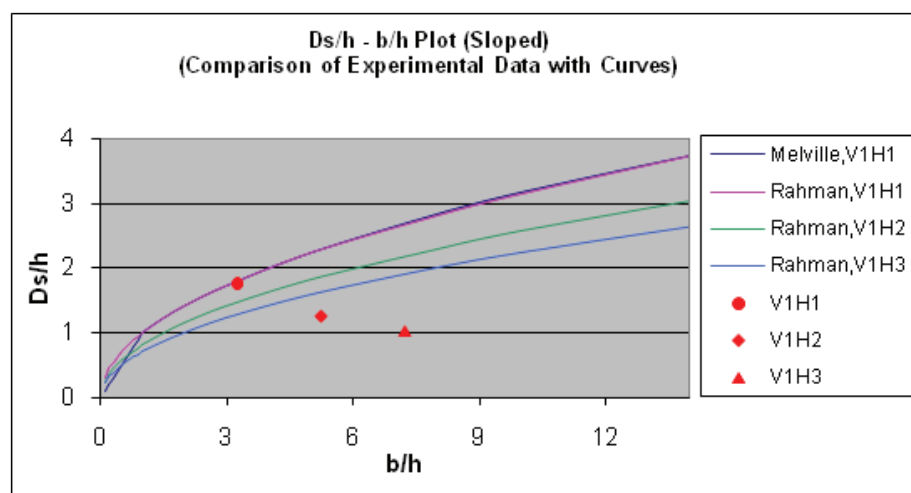

**Fig 15.** Comparison of experimental data with curves (Sloped)



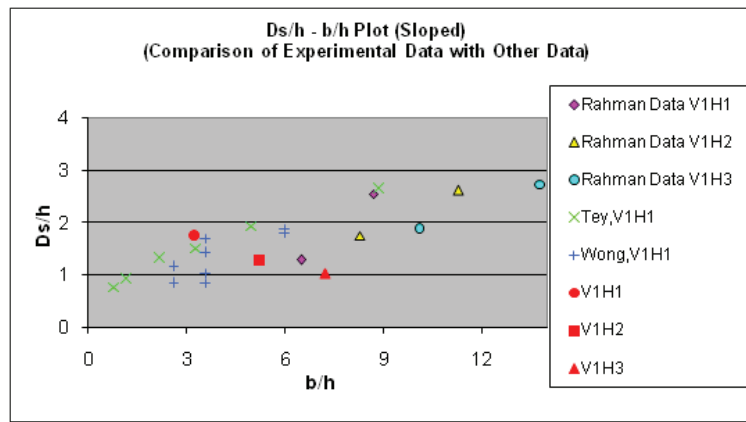

**Fig 16.** Comparison of experimental data with curves (Sloped)

**3.4 Effect of Submerged Flow Restriction**

**3.5 Scour Profile Variation**

Submerged flow restriction is the restriction to flow caused by the apron material. The restriction is not catered for in the existing formula for calculation of scour depth measurement.

Longitudinal / lateral profile for vertical abutments show the location, depth and shape of scour hole and are shown in Fig. 17 and 18.

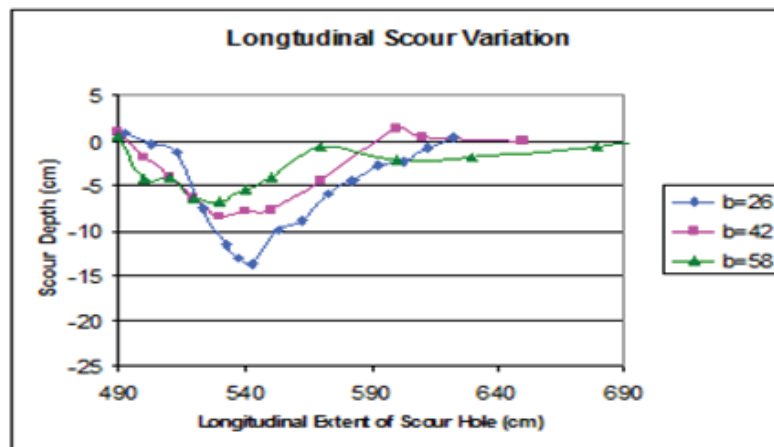

**Fig 17.** Longitudinal scour variation for vertical abutments

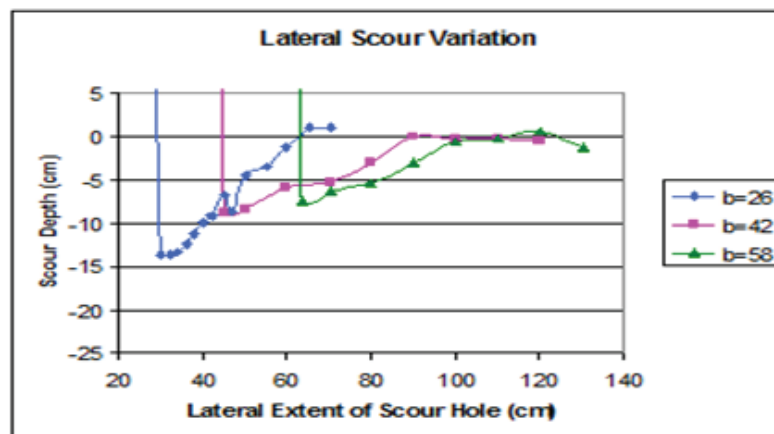

**Fig 18.** Lateral scour variation for vertical abutments

Similarly, Longitudinal / Lateral profile for sloping abutments are shown in Fig. 19 and 20.

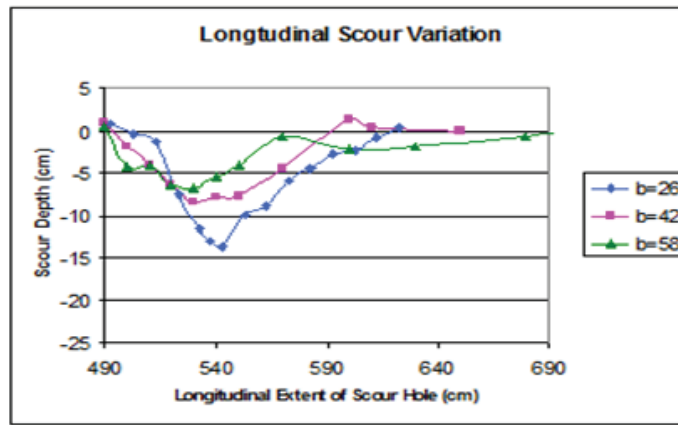

Fig 19. Longitudinal scour variation for sloping abutments

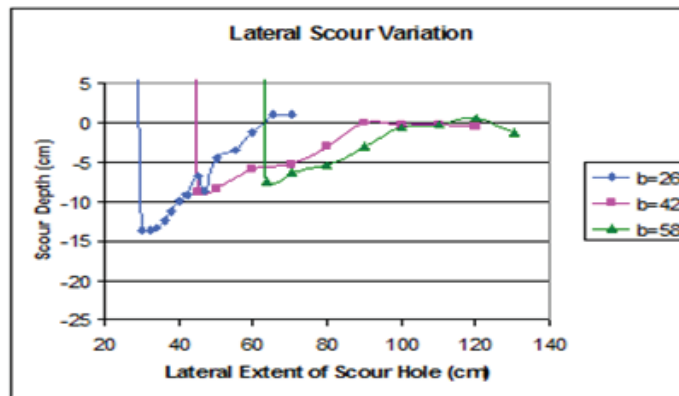

Fig 20. Lateral scour variation for sloping abutments

**4.0 DISCUSSION**

**4.1 Behaviour of Launching Apron**

**4.1.1 Scour slope and location of maximum scour depth – effect on protection of structure**

From the study of launching apron, it is seen that the scour hole produced is away from the structure. The location is towards the downstream side of the structure. The scour hole has been stabilised by both the angle of repose of bed material and launched apron material on the scour slope. The scour depth and the angle of repose of bed material determine the extent of scour hole. When this extent reaches the apron material then apron has been launched. Therefore, the launching apron probably protects the structure around which it is laid in two ways: one is by forming a protective layer on the scour hole slope and the other is by forcing the scour hole to form away from the structure. Fig. 21 shows the state of apron material on the scour hole slope after it is launched.



Fig 21. State of apron material on the scour hole

**4.1.2 Downstream side – deposition – economy – sudden flow**

By the pattern of apron laying it was observed that economy can be achieved on the downstream side of structure. However, the safe extent limit needs further study. Sometimes, sudden flow has been

given and it has been observed that during sudden flow the deposition got washed away and fresh deposition occurred later. Fig. 22 shows that economy on required volume of apron material can be achieved on the downstream side of protected structure.



**Fig 22.** Apron material on the downstream side of protected structure

#### 4.1.3 Loss of material through pores of apron cubes

In one setting, apron cubes are used of bigger size than is calculated to be critical size. At that time, it has been observed that apron is launched mainly due to loss of bed material through the pores of cubes.

#### 4.2 Future application of this study

Very few studies have so far been conducted to examine the laboratory scale behaviour of launching apron in Bangladesh. Haque (2010) studied about the flow pattern for different types of launching apron and discharge on fixed bed and mobile bed. As this study was conducted on straight sand bed laboratory channel, similar study can be made under live-bed conditions to investigate more practical cases of Bangladesh. Study can be undertaken to find out new shape factor for sloping structures for which slopes end at initial bed level and then become vertical. For predicting the scour depth when apron material is laid, the effect of submerged flow restriction can be studied. From this, possibly the location of maximum scour depth can also be determined. Whether the loss of bed material can be prevented through the pores of

apron material or not that can be studied by widely varying the sizes of apron material. The biggest size might be determined from the maximum velocity that is to be encountered. The smallest size might be determined from bed material size. To achieve economy by laying less amount of apron on downstream side of structure, how much will be the safe extent for laying apron that may be studied.

## 5.0 CONCLUSIONS

An in-depth study has been carried out to examine the role of launching apron in a straight sand bed laboratory channel. Based on the forgoing deliberation and subsequent discussions the following conclusions may be drawn from the present study.

For scour depth prediction around sloping structures without apron, the existing formulae either use shape factors or the slope angle of the structures. However, these formulae are suitable for structures having the slope up to a level below the maximum scour depth that might occur. When the structures have, a sloping face up to the initial bed level and then these are made vertical, the existing formulae might not give correct result. The shape factors in this case are probably not truly representative of the structures concerned. Therefore, for this type of case either new shape factors need to be found out or existing formulae need some modification. In the available scour depth prediction formulae, the flow restriction width, 'b' is an important criterion. This 'b' is calculated from the dimensions of original structure. But when launching apron is laid to protect the structure, the laid apron material becomes another submerged structure that also restricts the flow. Since the additional flow restriction happens in a submerged condition, it is not readily understood from above the surface. However, the effect of the submerged flow restriction is quite significant. Therefore, while designing launching apron, the submerged flow restriction width that is provided by the laid launching apron need to be considered for scour depth prediction. In case of sloping structures, the effect of slope is more prominent than that of flow restriction width. When 'b' is increased, the scour

depth should also increase. But at the same time if the slope of the structure is made milder, then the scour depth does not increase. Instead, the scour depth is decreased. However, the combined effect needs to be found out and for that accurate shape factor is required. The apron material seems to protect the structure, around which it is laid, in two ways. First, by creating a protective layer on the sloping face of scour hole. Second, by allowing the scour hole to be developed away from the structure. For bigger apron material, uneven settlement occurs due to loss of bed material through the pores of apron material.

**6.0 ACKNOWLEDGEMENT:** First author would like to express sincere gratitude to Bangladesh Army for granting study leave as well as providing financial support to pursue MSc in Water Resources Engineering at BUET

## 7.0 REFERENCES

- [1] Barkdoll, B. D., Ettema, R. and Melville, B. W., (2007) "Countermeasures to protect bridge abutments from scour", National Cooperative Highway Research Program (NCHRP), Washington, D. C. Report No. 587. (<https://book.google.com.bd/books?isbn=0309098955>)
- [2] Breusers, H. N. C. and Raudkivi, A. J., "Scouring", A. A. (1991). Balkema Publishers, Rotterdam, Netherlands.
- [3] Das U K A (2016) Case Study on Performance of JiaBharali River Bank Protection Measure Using Geotextile Bags. Int. J. of Geosynth.and Ground Eng. (2016) 2: 12. doi:10.1007/s40891-016-0052-8
- [4] Gales, R., (1938). "The Principles of river training for railway bridges and their application to the case of Hardinge Bridge over the Lower Ganges at Sara", Journal of the Institution of Civil Engineers, December, Paper No. 5167.
- [5] Gill, M. K.,(1972) "Erosion of sand beds around spur dikes", Journal of Hydraulic Division, ASCE, Vol. 98, Hy 9, pp. 1587-1602.
- [6] Hossain, M. M., (1981) "Study of river bank stabilisation in a bend by groin", MSc. Engineering Thesis, BUET, Dhaka, July.
- [7] Haque, M.E., (2010) "Experimental study on flow behaviour around launching apron", MSc. Engineering Thesis, BUET, Dhaka, January.
- [8] Inglis, Sir. C. (1949),"The behaviour and control of rivers and canals." Research Publication No. 13, Central Waterpower, Irrigation and Navigation Research Station (now Central Water and Power Research Station), Pune, pp. 380 and 369.
- [9] Joglekar, D. V., (1971) "Manual on river behaviour control and training", Publication No. 60 (Revised), Central Board of Irrigation and Power, New Delhi, pp. 222-241.
- [9] Melville, B. W.,(1992) "Local scour at bridge abutments", Journal of Hydraulic Division, ASCE, 118 (4), pp. 615-631.
- [10] Melville, B. W. and Coleman, S. E., (2000) "Bridge Scour", Water Resources Publications, Colorado, USA.
- [11] Neill, C. R., (1975) "Guide to bridge hydraulics, Project Committee Bridge Hydraulics", Roads and Transportation Association of Canada, chapter 5, 1975.
- [12] Novak, P, Moffat, AIB, Nalluri, G and Narayanan, R (2007).Hydraulic Structures, 4th Edition, Taylors & Francis group, London.
- [13] Oberhagemann, K., Diggelmann, P. and Mukhles-uz-Zaman, (2008). "Understanding falling aprons – experience from the lower Brahmaputra/Jamuna river", 4th International Conference on Scour and Erosion, Technical Paper, 2008. ([http://vzb.baw.de/publikationen/tc213/0/b\\_9.pdf](http://vzb.baw.de/publikationen/tc213/0/b_9.pdf))
- [14] Rahman, M. M.,(1998)."Studies on deformation process of meandering channels and local scouring around spur-dike-like structures", Doctoral Thesis, Kyoto, Japan, December 1998.
- [15] Rao, T. S. N., (1946). "History of the Hardinge Bridge up to 1941", Railway Board, Government of India, New Delhi, Technical Paper No. 318, pp. 42-50.
- [16] Spring, F. J. E. (1903), "River training and control of the guide bank system", Railway Board, Government of India, New Delhi, Technical Paper No. 153.