

# CHAPTER 1

## INTRODUCTION

### 1.1 General

Mode choice is usually an application of users' decision making process of choosing different modes for particular types of trips. The choice of mode is one of the most important classic models in transportation planning. It is closely associated with the commuters' choice making process which is one of the most important aspects of the transportation modeling in order to predict the choice behavior for travel decisions. This is because of the key role played by transport in policy making (Ortúzar and Willumsen, 2001). The important concept of travel mode choice models is to understand the relationship between traveler's motivation to choose a mode and the underlying attributes of the choice, such as service quality of modes, accessibility, cost, travel time, waiting time, number and ease of transfers, comfort, etc. (Ben-Akiva and Lerman, 1985; Koppleman and Wen, 2000).

Trip chain may be defined as a sequence of trips that starts at home, involves visit one or more other places, and ends at home (Timmermans et al. 2003; Ye et al. 2007; Primerano et al. 2008). Lee et al. (2007) suggests that a trip chain comprises at least two out-of-home activities that are connected by travel after leaving home until returning home in a single 24-h day. Trip chain may be classified into two categories depending on the number of visits during a trip chain: simple and complex. Simple trip chain may be considered as a trip for a single work with only one stopover; however a trip with more than one stopover may be considered as complex chain. Examples of simple and complex trip chains are: Simple chain: home - shop - home and Complex chain: home - work - shop - home. Trip chain analysis

symbolizes the travel behavior in a better way and provides various frameworks that may help to examine different transportation issues (Strathman & Dueker, 1995).

Historically, cities have always been the engines of economic development, industrial and commercial centres (Brockerhoff, 2000). According to Rodrigue et al, (2009), cities are high level of accumulation and concentration of economic activities and are complex spatial structures supported by transport systems. Transport, however, is one of the most important means to make urban resident life comfortable. Nevertheless, an efficient and effective urban transport system is a means of promoting urban development as well as providing access and mobility to urban residents (Kwakye et al, 1997). Urban transport planning can therefore be regarded as an important activity for promotional mobility (Hasan, 2007) and national growth process. This process requires estimates of current and forecasts of travel on the transport system, including highways, transit, non-motorized and freight modes. These travel forecasts are generally realized through computer-driven network simulations of the transport system, known as travel demand forecast models. Travel forecast models are used to study the proposed investment in the transport system and determine which of these investments will provide the best public needs for future travel and economic development. The models are also used to evaluate the real effects of alternative land use scenarios. In this way, travel modeling or prediction is an important task to identify needs for improving the city's infrastructure (Chen, 2007). Mode selection analysis is one of the most important and challenging components of the conventional four-steps travel model process.

Many practical transport policy issues relate to mode choices. For example, the profit or loss in transit revenue caused by traffic increase depends on how travelers' mode choices are affected. Similarly, the effects of changes to routes and schedules on driving, income and traffic jams are all dependent on how changes affect individual traveler choices. An understanding of the separate and combined effects of these decisions in the choice of travel mode is essential for selecting the best plan to achieve specific transport goals (Horowitz et al, 1986).

Therefore, the issue of mode choice is probably the most important element in transport planning and policy making. It affects the overall efficiency of travel in urban areas, the amount of urban space spent on transport functions, as well as a number of choices available to travelers. It is then important to develop and use models that are sensitive to those characteristics of trips that influence individual choices of mode (Ortúzar & Willumsen, 2001).

## **1.2 Problem Identification**

Rapid industrialization and socialization led to higher growth rates, higher income and excessive demand for mobility in developing cities. Increasing transports cause congestion and environmental problems that create disruption in traffic condition like delay and accidents resulting significant economic loss every year. Now-a-days traffic congestion is a matter of great concern for the inhabitants of Dhaka resulting in user's annoyance, lengthier travel times and air pollution.

Dhaka is one of the fastest growing mega cities in the world, but has a serious lack of transport facilities for its residents. Dhaka's transportation system is predominantly road based. Dhaka's traffic system is known as heterogeneous traffic system due to the wide variation in the operation and performance characteristics of motorized, non-motorized, slow-moving or fast-moving vehicles sharing the same road space (Karim et al, 1998). A recent World Bank study (2017) shows that Dhaka's average traffic speed has dropped from 21 km/h to 7 km/h in the last 10 years, slightly above the average walking speed. Traffic gridlock eats up 3.2 million work hours per day. Another study conducted by the Copenhagen Consensus Center (2017) says that the speed in Dhaka is now 6.4km/h, and that if vehicle growth continues at its current pace, without substantial public transport the average speed may fall to 4.7 Km/h by 2035. The government has already revised the Strategic Transport Plan (STP) for 20 years (2015-2035) to enhance traffic speed.

Increasing physical capacity is a very difficult option to solve traffic system for the city, as the ratio of urban areas has already reached 70% (Bari & Hasan, 2001). Therefore, the solution to the problem requires increasing capacity by demand and supply management. The current state of the transport system in Dhaka primarily constitute of vehicles such as non-motorized transportation mainly rickshaws, which as a substantial share with the number being more than 50,000. On the other hand, the level of motorization is very low compared to similar cities (Rahman, 2008). Dhaka is one of the most densely populated areas in the world with a density of 23,234 people per square kilometer with a total area of 300 square kilometers (Bangladesh Bureau of statistics). Dhaka Metropolitan city is bounded by 3 large rivers mainly river Buriganga, Balu and Turag (figure-1). The road network in Dhaka is

nearly 3,000 km with 200 km primary, 110 km secondary, 50 km feeder, 2640 km of narrow roads and few alternative routes. The proportion of the road to the built-up area is hardly 7% compared with 25% recommended for a good city planning. Traffic jam has affected people's lives by causing both physical and mental stress. Congestion has increased travel costs directly due to the loss of time of passengers and indirectly due to increased costs in system operation.



Figure 1: Dhaka City Map

Various researches have been carried out on travel behavior and mode choice of traveller of Dhaka city but at present a comprehensive study on mode choice for working people in Dhaka city is very much essential. Moreover, in the recent years SEM is used in the field of transportation planning. SEM has been used empirically to examine the relationship of residential neighbourhood type to travel behaviour, incorporating attitudinal, lifestyle and demographic variables (Bagley and Mokhtarian, 2002) and recently to explore whether changes in neighbourhood characteristics bring about changes in travel choice (Aditjandra et al, 2012).

Users have diverse sensitivity concerning the service related attributes of modes. It is essential to comprehend user's motivations for using a particular mode for implementing suitable transport strategies aimed at resolving the congestion, identifying the sensitivity towards the attributes and associated trade-offs for various travel attributes. Developing cities like Dhaka barely explores the reasons for choosing different modes and often employed the mode choice models that are used in developed countries.

### **1.3 Objectives of the Study**

The specific objectives of this research:

- i. To investigate the relationships among the major attributes that affect mode choice and trip chaining by structural equation modeling.
- ii. To study the mode choice behavior and its contributing factor in Dhaka city.

### **1.4 Organization of the Thesis**

The thesis consists of six chapters including the present one. The first chapter deals with the introduction, problem identification and objectives of the study. Chapter 2 presents literature review on the theme of this study. Chapter 3 gives details of research methodology. Chapter 4 is devoted to the data analysis of mode choice behavior in respect of different socio-economic characteristics. Chapter 5 deals with model development and result analysis. Finally, summary of the research work and conclusion is included in chapter 6. Future research scopes are also presented in it.

## **CHAPTER 2**

### **LITERATURE REVIEW**

#### **2.1 Introduction**

This chapter gives a brief overview of the travel behavior, trip chain and its factor that influence choice of travel mode, few common mode choice models. It also attempts to collect some mode-related studies in different cities of developing countries. The literature on transportation related studies so far conducted for Dhaka City has been presented at the last part of this chapter.

#### **2.2 Trip Behavior**

Human activities are not concentrated at one place, and there is a need to travel from one place to another place for their livelihoods. Demand for travel is a requirement. Except for certain recreational purposes, people do not ask for travel for their own account. Instead, they demand such daily activities as work, shopping and education; and travel allow them to achieve these activities (Meyer & Miller, 2001). Therefore, the travel behavior is a study of what people do over space and how people use transport. But this is a complex phenomenon that largely depends on a number of factors such as personal/household characteristics of travelers, socioeconomic features, trips, places of origin and destination under the time limits, cost, comfort, availability and so on (Takyi, 1990).

### 2.3 Trip Chain

Trips are the main basis for transportation models. Trip chain may be defined as number of trips that takes place in a day. Trip chain may be classified into two categories; simple trip chain and complex trip chain. Few schematic diagrams of trip chain are shown below:

Simple home to work ; work to home h-w(-w)-h trip chain



Figure 2.1: h-w(-w)-h trip chain

One non-work stop from home to work and one non-work stop from work to home h-nw-w(-w)-nw-h trip chain

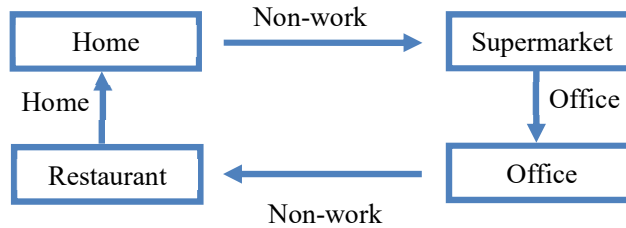

Figure 2.2: h-nw-w(-w)-nw-h trip chain

No non-work stop from home to work but one non-work stop from work to home h-w(-w)-nw-h trip chain

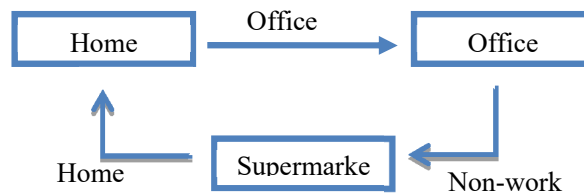

Figure 2.3: h-w(-w)-nw-h trip chain

No non-work from home to work but more than two non-work stop from work to home h-w(-w)-nw-nw(-nw)-h trip chain

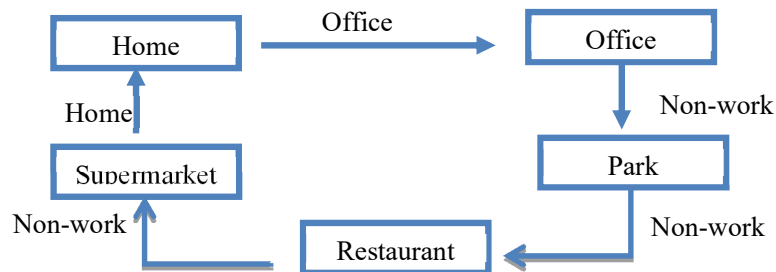

Figure 2.4: h-w(-w)-nw-nw(-nw)-h trip chain



## **2.4 Factors that Influence Choice of Travel Mode**

The choice of travel mode is influenced by many factors. These factors are classified in many different ways by Olsson, (2003). Some of these are described below:

### **2.4.1. Hard and Soft Factors**

Hard factors are usually found in the traditional travel mode choice models based on maximization of utility. Examples of hard factors include travel time, waiting time and ticket price (rate). Soft factors are things like comfort, service and information. Soft factors can also be psychological, for example flexibility, ease of orientation, etc. (Loncar-Lucassi, 1998).

### **2.4.2. Internal and External Factors**

Factors that determine the choice of travel mode can also be divided into internal and external factors. Internal factors include attitudes, socio-economic and demographic factors, habits and perceived level of control. External factors include travel time and travel costs (Nilsson, 1998).

### **2.4.3. Subjective and Objective Factors**

Objective factors are usually based on objective, easy to measure and quantify. Examples of other objective factors are weather, topography, safety and the environment. Subjective factors include evaluations of the characteristics of the alternative, attitudes and lifestyle. These factors are based on the perception of the individual and are often more difficult to quantify (Rystam, 1998).

### **2.4.4. Transport-Specific Factors**

Transport-specific factors are related to the different parts of the transport system, for example, lanes, proximity to stops and stations, congestion charges, service level, proximity to the cycle road network and accessibility. In addition to travel time, fare, comfort and information, whether transport-related factors also include station-related factors such as the

overall appearance of stations and stops. These factors are mainly influenced by local government, businesses, operators, and the home and workplace of the individual and the choice of travel mode (Magelund, 1997).

#### 2.4.5. Environmental-Specific Factors

Environmental-specific factors describe the environment of the route taken, that is, the things that are not part of the transport system; the topography, weather access to shops and schools etc (Magelund, 1997).

#### 2.4.6. Individual-Specific Factors

Individual specific factors are factors that describe not only the characteristics of the individual and the personality, but also to a certain extent the entire household. Such factors include socio-economic factors such as age and sex, as well as attitudes, status and habits. The lifestyle of a person is also an individually related factor. Gender and age are predetermined, while attitudes and lifestyle can be more easily influenced (Magelund, 1997).

#### 2.4.7. Quality Factors

Quality factors are factors related to the individual's perception of the journey and the standard of the transportation system. The safety and security factor is an example of a quality factor. Both the individual and central government can influence these factors (Magelund, 1997).

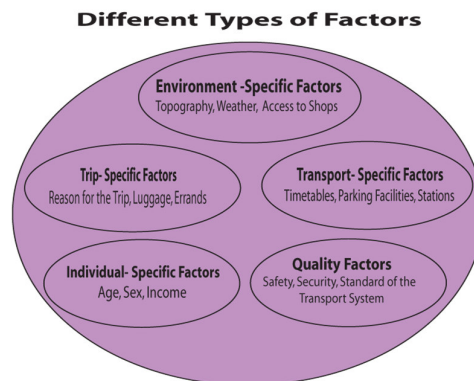

Figure 2.5: Factors Influence Choice of Travel Mode

## 2.5 Mode Choice Model

Mode choice is the process when the means of traveling is determined with the origin and destinations are already known. Mode choice is usually an application of users' decision making process of choosing different modes for particular types of trips. Mode choice models for forecasting travel demand have been developed by several researchers in the last few decades (Ben-Akiva and Lerman, 1985; Train, 1998). Habib (2002) developed a four-steps travel demand model for Dhaka city (Dhaka urban transport model, DUTM). The results showed that they were counterintuitive with positive sign of the coefficients or time and cost parameters. In his study, it was found that coefficient for comfort is greater than that of time and cost which is not usual for developing countries like Bangladesh. A mode choice model for the work trips of middle income group of Dhaka city was developed by Aftabuzzaman et al. (2010). Result showed a rise in the modal share of bus and fall in the share of rickshaw and auto rickshaw. Gopinath (1995) presents latent class models for mode choice behavior and shows that different segments of population have different decision protocols before the choice process as well as different sensitivities for time and cost.

Mode choice models are closely linked with individual's mode choice behavior which continues to attract attention for further exploration of the choice making process (Sekhar, 2014). Travelers' mode choice decisions and the influencing factors have been investigated in many studies (Train and McFadden, 1976; 1978; Bordagaray et al. 2014). Logit models have been widely employed on mode choice decisions. (Anas, 1983; Ben-Akiva, 1999; Walker, 2001). Disaggregated demand models are used to reveal the variables that influence user's choice and to ascertain the probability of choosing different available options used (McFadden, 1981; Schakenbos et al. 2016). The majority of the models developed for travel behavior functions are based on random utility theory (McFadden, 1974; Domencich and McFadden, 1975; Manski, 1977; de Dios Ortúza and Willumsen, 2001), which presumes that

the preference of choice of an alternative is considered by utility, and decision of selection is done based on the most satisfactory choice (Taniguchi et al. 2014). The essential concept of travel mode choice models is to understand the relationship between traveler's choice and the contributing factors, such as the social-economic level and service level of modes (Ding and Zhang, 2015).

### **2.5.1 Discrete Choice Modeling**

Discrete choice methods have been used for the development of mode selection models for years (TRB, 2007). These models are called Discrete-choice models because most such models analyze choices between discrete and non-continuous alternatives (Small 2005). These models are also referred to as disaggregate models, which means that the decision maker becomes an individual (Ben-Akiva & Berlaire, 1999), as travel decisions are individual, not by traffic analysis zones (Domencich & McFadden, 1975).

### **2.5.2 Random Utility Model (RUM)**

The hypothesis that lies with RUM is that when faced with a choice situation, an individual's preference for each alternative can be described by an "attractiveness" or "utility" measure that is linked to each alternative. The help function generates a numeric value or score based on different attributes of travel mode and travel agent features. The decision-maker is based on choosing the alternative that provides the highest benefit. Utilities, however, can't be directly observed or measured (Ben-Akiva and Lerman, 1985). In addition, the name "randomly" means that the decision maker has the perfect discrimination, i.e. the analyst has incomplete information about the choice. Therefore, in the help function, uncertainty must be taken into account. Manski, (1973) identified four different sources of uncertainty: unnoticed alternative attributes, unnoticed individual attributes (or unnoticed flavor variations), measurement errors, and imperfect information, and instrumental (or proxy) variables.

### **2.5.3 Multinomial Probit Model**

The Multinomial Probability Unit or Multinomial Probit (MNP) model is derived from the assumption that the error terms of the utility functions are normally distributed. The Probit model captures explicitly the correlation among all alternatives. Therefore, a vector notation is applied for the utility functions (Ben-Akiva and Bierlaire, 1999).

### **2.5.4 Multinomial Logit Model**

The simplest and most widely used discrete option is the Logistics Probability Unit, or the Logit Model (Train & McFadden, 1978), which was first introduced in the binary selection based on logistics distribution. The generalization of more than two alternatives is called the multinomial logit (MNL) model. The popularity of the MNL is due to the fact that the formula for choice probabilities has a closed form and can easily be clarified (Train, 2003). Originally, the logit formula was derived by Luce (1959) and later, Marschak (1960) showed that the model is consistent with the use maximization. McFadden (1977) completed the analysis with the necessary underlying assumptions for the choice probabilities.

The specific assumptions that lead to the MNL model are (Koppelman & Bhat, 2006):

- i. The error components are distributed extensively (or Gumbel);
- ii. The error components are identical and independently distributed over alternatives;
- iii. The error components are distributed identically and independently across observations or individuals.

### **2.5.5 Nested Logit Model**

The idea of the nested logit model lies in the grouping of similar alternatives in nests, thus creating a hierarchical structure of the alternatives (Ben-Akiva & Lerman, 1985). Train (2003) explains the statement by using the term 'matched' with nested logit model when the set of alternatives that a decelerator faces can be divided into subsets called nests in such a way that they hold the following properties:

- i. For all alternatives that are in the same nest, the relationship between probabilities is independent of the attributes or the presence of all other alternatives.
- ii. For possible alternatives in different nests, the relationship between probabilities may depend on attributes of other alternatives in the two zeros.

### **2.5.6 Structural Equation Modeling**

Structural Equation Modeling (SEM) contains a variety of mathematical models, computer algorithms and statistical methods that match networking of constructs to data. SEM includes affirmative factors analysis, partial least square path modeling and latent growth modeling. Structural comparison models are often used to assess unobservable 'latent' constructs. They often call a measurement model that defines latent variables using one or more observed variables, and a structural model that implies relationships between latent variables. The links between constructs of a structural equation model can be estimated by independent regression equation or by more involved approaches, such as those used in Linear Structural Relation (LISREL).

The use of SEM is often justified in social sciences because of the ability to imply relationships between unresolved constructs (latent variables) of perceptible variables. To give a simple example, the concept of human intelligence can't be measured directly because

one can measure height or weight. Instead, psychologists develop a hypothesis of intelligence and write measuring instruments with items (questions) designed to measure intelligence according to their hypothesis. They would then use SEM to test their hypothesis using data collected from people who took their intelligence test. With SEM, "intelligence" would be the latent variable and the test items would be the observed variables.

One of the strengths of SEM is its flexibility, which permits examination of complex associations of various types of data (e.g. categorical, dimensional, censored, count variables), and comparisons across alternative models. However, general guidelines and requirements are difficult to develop because of these features of SEM (MacCallum et al, 1999). Model characteristics such as the level of communality across the variables, sample size, and degree of factor determinacy affect the accuracy of the parameter estimates and model fit statistics, which raises doubts about applying sample size rules-of-thumb to a specific SEM (MacCallum et al. 1999).

## **2.6 Studies on Mode Choice Behavior and Model in Developing Countries**

### **2.6.1 Shanghai, China**

Ho et al. (1999) presented an urban transport planning model developed for the base year 1995 in Shanghai. They developed a model framework that consists of a series of model elements with relatively simple structures, so that the models can easily be calibrated, updated, implemented and applied. The model considered different types of variables that can effectively reflect regional economic growth, as well as urban and transport development in Shanghai. The model was a sequential process consisting of trip generation, travel distribution, modal split and traffic assignment. A special feature of this model framework was that the modal split procedure is divided into three sub-models that must be performed separately before or after the travel distribution model. The hikes and personal motorized

trips were determined for the travel distribution model. The rest of the trips were split between the bicycle and the transit (bus, rail) after the travel distribution model. The two-stage modal split process separated different travel market segments (walking, personal motorized and bicycle/transit) with different travel features in the early stage of the modeling process. The models can therefore handle the trips of different market segments with another individual model element with the right structure and variables.

Liu (2006) analyzed travelers' choice behavior using data from a stated preference survey on work-trip mode choice in Shanghai. Several versions of a multinomial choice model were specified and estimated. According to the estimation results, the cost-sharing auxiliary function is divided by income adjusted by an equivalent scale chosen as the preferred model.

### **2.6.2 Hyderabad, India**

Environment Protection Training and Research Institute (2005) developed a 4-steps transport demand model for Hyderabad, which is one of the fastest growing centers of urban development in India. In the modal split stage, separate models were developed for respondents who did not have access to any individual vehicle, those who had access to 2-wheelers and who had access to cars. A multinomial logit model has been developed to empirically investigate how travelers alternate among the characteristics of price, time and reliability. Stated preference (SP) research was conducted to know the modal preferences of respondents. The results of the SP survey analysis show that travelers are relatively more sensitive to time and reliability, and relatively less costly. Reliability for all groups is relatively more important than time.



### **2.6.3 Chennai, India**

Srinivasan & Rogers (2005) investigated the travel behavior of income residents from two contrasting locations in Chennai, India. Travel behavior and the relationship to urban form are the focus of this study. They analyzed the differences in travel behavior due to differences in accessibility for work and services between the two sites. The results show that differences in accessibility strongly influence the behavior of the trip. Residents in the central settlement were more likely to use non-motorized modes to travel (walk or cycle) than the peripheral inhabitants. She suggested that policy makers from developing countries like India should consider the place of employment in planning new homes for low-income households.

In this study two separate models were developed to investigate the city's travel behavior. In order to understand the determinants of travel behavior, discrete choice models were estimated for mode selection and travel frequency. The models were estimated by individual for mode choice and by households for travel frequency. For the mode choice model, the choice is between NMT, combined transit (bus) and NMT and private vehicle (including three wheels and two wheels). The model censored mode selection. Thus, in the absence of a bus route to the destination, the implication is that the mode bus will not be included as a mode selection for the person. Similarly, if the household had no vehicle, the choice of private vehicle was not available to them. The model was estimated separately for persons with jobs and for all persons. The travel rate model is estimated as a binary option between less than or average travel rates versus more than average travel (per person and per household).

### **2.6.4 Kuala Lumpur, Malaysia**

In order to analyze a policy to improve public transport, as well as car traffic control in Kuala Lumpur, Nurdeen et al. (2007), developed mode-select models to express the behavior of car

users and public transport and to investigate their response such as the likelihood that motorists move to public transport based on a scenario of a reduction in bus and train time and travel costs. A binary logit model has been developed for the three alternative modes, bus, train and car. It has been found that travel time, travel expenses, gender, age, income level and car traffic are significant in influencing the mode select behavior of car users. The reduction in total travel time and travel costs for bus and train mode is reflected as the most important element in a program aimed at attracting car users in public transport and away from car mode.

#### **2.6.5 Addis Ababa, Ethiopia**

Gebeyehu & Takano (2007) analyzed the modal choice of residents of public transport and their perception of bus condition parameters as a determining factor for their bus choice in the city of Addis Ababa. The most important modalities of public transport in Addis Ababa are buses and taxis. There is no rail transport within the city. Existing public transport is of low quality due to the limited number of buses and taxis, poor management and bad behavior of drivers. This research is an important effort on these current urban transport problems. In this study, an ordered logit model was developed to explore the perceptions of citizens on bus conditions. The result shows that the perceptions of the citizens of the three chosen bus conditions have issues, convenience and frequency-significant influence on the choice of public transport.

#### **2.6.6 Yangon, Myanmar**

Zhang et al. (2008) tried to analyze mode choice behavior based on a specified preference (SP) survey in Yangon city, Myanmar. There are four types of transport modes available in Yangon: car, train, taxi and bus. In developing countries, the socioeconomic environments (especially income) change rapidly and therefore the influence of such decision-making

context must reflect both the research method and the modeling framework. In view of the fact, SP survey was designed and implemented for the first time to integrate the impact of future income, as well as other levels of service attributes, while also making a noted revealed preference (RP) survey. After estimating the reliability of SP data by estimating the SP model, an RP / SP combined mode option model was estimated in which the travel time and cost parameters were defined as a function of future income, respectively. The effectiveness of the proposed model structure was confirmed empirically. Furthermore, simulation analysis for that future income would lead to a potentially large increase in the use of cars and, consequently, the reduction of transit systems.

## **2.7 Transport Planning Related Studies in Dhaka City**

It is absolutely necessary to assess the past studies to have an idea of transport planning, analysis of travel behavior. This section gives a brief overview of those studies.

### **2.7.1 Transport Planning and Policy-related Study**

The first study on transport planning and development "Dhaka City Master Plan" was established in 1959 by monitoring the former Dhaka Improvement Trust (DIT), which was approximately 830 square kilometers with an audience of more than a million, with an average annual population growth rate of 1.75% in the urban areas is assumed. It provided a detailed plan for the future expansion of the city and road construction (RAJUK, 2010). The second study began in 1979 with the DMAIUDP (Dhaka Metropolitan Area Integrated Urban Development Plan) and aimed at drawing up a Dhaka strategy plan, including transport development, which emphasized road network construction and management. It also described physical characteristics such as capital costs, vehicle life and capacity of different modes in the study area.

The integrated transport study Greater Dhaka Metropolitan Area (DITS) (1991-1993) was an initiative of the Bangladesh government (GOB) with the help of UNDP. The purpose of the project was to gather information on the demand for transport services and infrastructure to provide these services mode to Dhaka, to draw up an immediate action plan for the effective management of the existing traffic and transport system, and to provide a good basis for strategic planning of long-term infrastructure investment in the Greater Dhaka Metropolitan Area. DITS produced numerous recommendations within the immediate action plan (IAP). Recommendations have complemented projects that vary from strategic policy advice involving little or no capital investment expenditures. Mohakhali and Khilgaon flyovers were built in 2004 and 2005 under DITS recommendations to reduce congestion. But in turn, Mohakahli flyover has achieved little success in minimizing congestion; rather, the situation worsens in some places, especially during peak hours. However, Khilgaon flyover performs relatively well in reducing severe congestion in some compounds (Hasan, 2007).

The Dhaka Urban Transport Project (DUTP) is from the recommendations of the DITS study. The objectives of the project were to improve the urban transport infrastructure and services in the Dhaka Metropolitan Area in an economically and environmentally friendly manner; strengthening the institutional and capacity building of the organizations involved in transport issues; And address the long-term transport planning and coordination issues in the Dhaka Metropolitan Area (DMA). With a new perspective, the Dhaka Metropolitan Development Plan (DMDP) was prepared for sustainable growth of Dhaka.

The plan addressed Dhaka's urban planning problems at three geographic levels: sub-regional, urban and sub-urban and consists of the three components. The first component, "The Structure Plan", provided a long-term strategy for 20 years (1995-2015) for the development of the larger Dhaka subzone with a population of 15 million. The main objective of the strategy was to establish a long-term road network for the urban area that

could effectively serve the needs of growing urban concentrations by providing better access to the main urban region itself and links to areas with growth potential. The second part, "The Urban Area Plan", provided an interim strategy for the ten-year period (1995-2005) for the development of urban areas in Metropolitan Dhaka. The third part, the Detailed Area Plan, provided detailed planning proposals and transport network for specific sub-areas of Dhaka, (RAJUK website). Habib (2002) has evaluated alternative planning options such as elimination of rickshaw and auto rickshaws, Improvement of the road network, improvement of bus transit and introduction of the rail transit system and their impact in Dhaka's traffic congestion and air pollution.

In 2004, a project by the GOB under the auspices of the World Bank (WB) was prepared for a long-term strategic transport plan (STP) for the Dhaka Metropolitan Area. An important goal of the STP was to establish a sound policy framework to ensure the sustainability of current and future investment in the transport sector. Critical to this goal was the preparation of a long term (20 years) and a multimodal transport plan for the larger Dhaka area, based on an assessment of the interrelationship between land use and transport. The plan covers extensive policy issues, including pedestrians, public transport, non-motorized transport, development policy and urban transport strategies, including traffic management, parking, land use - Transport Planning, institutional and financial aspects and so on.

At present, a project called "Dhaka Urban Transport Network Development Study" (DHUTS) has been conducted by the Dhaka Transport Co-ordination Council (DTCCB) with technical cooperation from Japan's International Cooperation Agency (JICA). The objectives of the DHUTS research are to develop an urban transport development plan that is integrated with DMA's urban development plan for the period up to 2025, to provide a general perimeter of the urban transport projects implemented on a priority basis to propose the role of the Project Implementation Agency and the Operation/Maintenance/Management Agency and the

development of their implementation capacity to provide an overview of the feasibility study plan for the construction of the urban transport system.

The study area of the project concerns the DMA in the area, surrounded by rivers Turag, Balu and Buriganaga, and includes Dhaka, the northern side and the east of Dhaka's outskirts. The major difference between STP and DHUTS study is that STP focuses on formulating comprehensive and sustainable urban transport policy and strategic transport plans for DMA. DMA strives to implement effective measures and actions for the implementation of urban transport projects with special attention to development of mass transit.

### **2.7.2 Travel-related Study**

Ara (1983) examined the factors responsible for selecting a particular transport mode. In particular, he analyzed the travel behavior of certain locations in the metropolitan Dhaka. It was found that the total family income was the most important factor in determining the choice of members of the correct transport mode for different travel purposes. Other factors affecting the travel mode selection were age and gender, car ownership, etc. In the study of DITS (1993), the behavior of the people of Dhaka city was revealed and reported as important findings, some of which are:

- i. Dhaka has very low motorization compared to other major cities in the world. About 60% of the trips are on foot, while almost half of the remaining trips are on cars with human use.
- ii. The average travel time in all modes is approximately 15 minutes and average transport costs range from about 8% of household income for high income groups (HIGs) to 17% for low income groups (LIGs).

iii. Large groups like women and urban poor have very poor access to transport services.

iv. Bus services based on large capacity vehicles are by far the most efficient way to provide public transport in Dhaka and also to address the special needs of women and LIGs.

In the study of STP (2004), the socio-economic and travel characteristics of the people of Dhaka city were shown by data collected by a household survey (HIS) with 6,035 households from Dhaka city area. The study shows that bus travel dominates 44% of all trips. At the same time DITS (1993) study showed that almost 60% of all trips are walking.

In the DHUTS study, a household interview survey was conducted in 18,110 HHs to obtain the daily travel characteristics of residents in 90 neighborhoods of DCC and adjacent areas. Travel behavior of individuals has been analyzed with the results of the research of seven points of view: socio-economic profile, travel production, travel destination, mode of transport, travel generation and attraction, origin and destination and travel length. The main findings of the study on the characteristics of people movements in Dhaka were: DMA residents have produced about 20.8 million trips daily. Out of 20.8 million trips, non-motorized transport (NMT), hiking and rickshaws, represent 58%. NMT has still played an important role in Dhaka. Without NMT, the public bus represents 71%. Higher income group (HIG) with household income over TK 50,000/- shares 20.4% of travel, which is much higher than HIG's travel rate in STP.

Few studies have been conducted on the service quality (SQ) of Public transport (PT) like bus, ferry, trains etc in Bangladesh. A SEM approach has been used to identifying the relationships among major attributes that affect the intercity train services in Bangladesh (Hadiuzzaman. et al. 2017). Out of eighteen observed variables, overall security, fitness of

compartment, female harassment and waiting place condition are found to be the variables which pre dominantly influence the service quality. In case of passenger ferry of Bangladesh (Khan. et al. 2018) 'Fitness of Ferry' has the greatest influence on ferry SQ which is followed by riding safely and comfort level. In case of para transit (Rahman. et al. 2016) punctuality and reliability, fitness of vehicles and travels cost are found to be the most significant observed variables that influence the SQ.

## **2.8 Mode Choice Model Development Related Study**

A main objective of the DITS study was to establish a framework for identifying long-term transport needs for Dhaka and to evaluate capital intensive proposals to meet these needs. The basis for this framework was to set up a transport planning model using the data collected from the various surveys of transport demand, infrastructure and system performance. The modes considered in the DITS model were walk, rickshaw, public transport and private motorized transport. The choice between multi modes was simplified in binary choices by considering walk versus public transport then car versus public transport or rickshaw trips and finally rickshaw versus public transport trips.

However, a binary option is suitable in situations where even competitive choices are available. But in Dhaka modes are not as competitive as walking is used for short distance travel or for trips where other alternatives are not available or affordable. Auto-ownership is very low in Dhaka compared to other cities; car travel is only made by persons who own cars and therefore it is not pragmatic to compare with the car's choice. Habib (2002) developed a Urban Transport Planning Model (UTP Model) System for Dhaka City Transport Planning in his study. As part of the model, the modal split model was developed using a multinomial logit approach. Four ways were considered: rickshaw, walking, bus and car. The utility comparison was formed with cost, time and comfort as variables. Estimated cost and time



coefficients have a positive sign indicating counter intensiveness. Comfort was used as a generic variable in the model. But in reality, comfort is usually regarded as a perception of individual to a particular mode and therefore it must be applied as a dummy-specific variable. As part of the STP project, an UTP model has been developed and used to predict future travel demand arising from different land use scenarios and transport strategies and predicting the performance of existing, dedicated and alternative development strategies for Dhaka's urban infrastructure Transport networks, services and policies. In the UTP model only two modes of transit and motorized (non-transit) modes were considered; no hikes and non-motorized trips were considered where an important part of the travels is made by rickshaw. Auto rickshaw and auto bike was not considered in the model by their limited number. But in practice it turned out that it was bigger than the car and then the taxi mode. The modal split model has been developed considering the travel time, travel expenses and income group as the relevant variables; not trip-purpose mode. Travel time had positive signs indicating the result of the intuitive result. The time for LIG was greater than that for MIG and HIG too, which is almost unreasonable. The chance of choosing a car per lower income group was estimated at 90%, which was simply illogical and impractical.

Hasan (2007) developed a travel questionnaire for Dhaka City. The modal split procedure has been done in two phases: pre-distribution and post-distribution modal split. In the pre-distribution phase two separate trip was considered. The first Walk and Intra Zonal Trip Split, which separated the total zonal trips to zonal walk and intra-zonal travel and zonal non-walk inter-zonal trips and then the second the Personal Motorized Trip Split that separated zonal total non-walk Inter- zonal trips to zonal personal motorized trips and zonal car rickshaw, rickshaw and transit. A total of 0.76 and 2.21 million trips have been found for personal motor vehicle travel, and intra-zone travel. A disaggregated multinomial logit model was developed for this post-distribution modal split modeling with rickshaw, auto-rickshaw and

transit modes. The model considered modal service features as independent variables in terms of travel time and travel costs of the three competitive modes. However, in this model, the effect of revenue on the choice of travel mode has not been proven, with revenue being the dominant factor in terms of the socioeconomic status of the users. With the three modes, possible nested logit structure like motorized mode (Auto Rickshaw, Transit) with Non-Motorized Mode (Rickshaw), Public Transport Mode with para-transit Mode (Auto Rickshaw, Rickshaw) etc. can be tested.

Andaleeb et al. (2007) used factor analysis and multiple regressions to discover significant factors affecting passenger satisfaction on bus SQ. Among eight factors identified, comfort levels, staff behavior, number of buses changed to reach destination, supervision and waiting facilities were found to have significant effects on passenger satisfaction.

Yesmin (2010) studied the mode choice behavior of the office workers in Dhaka using nested logit model. A variety of attributes related to socio-economic characteristics of the travelers, trip characteristics and transport facilities were used for model specification. About 250 office workers of three private organizations were surveyed and it was found that most of the travelers (around 52 percent) used public bus for traveling to and from the office. It is found from the study that mode choice was influenced by gender and female workers were more inclined to choose a comfortable mode.

In the DHUTS study, the mode choice model has been developed using the multivariate logit models for each income layer. A two-steps approach was adopted. In the first step, the explanatory variables were the constant term and the OD distance for rickshaw and others and in the second step the parameter estimation was made with the constant term and general costs in terms of travel time, access time, transport cost / time value and / or vehicle operating

cost / time value for the other mode estimated in step 1, which indicates the private car, bus and rickshaw. The constant term for step 1 was not reported. The t-value of the parameters for LIG and MIG, estimated in step 2, was not statistically significant. The study did not investigate the nested logit structure for mode choice. As in STP, DHUTS developed the modal split model based on the income group; not trip-purpose mode. From the revision of mode model development techniques in different countries and the lack of viability of the Dhaka model, it can be concluded that the model development approach must be based on travel objectives. An individual, regardless of his income, can choose a bus for work trips, while he / she is more likely to have another mode of recreational or educational travel. The nested logit model should have been attempted to determine the characteristics of individual vehicles or dominate the group characteristics of vehicles when choosing travel mode. A study on “Structural equation approach to investigate trip chaining and mode choice relationships in the context of developing countries” was carried out by Hadiuzzaman et al. (2019). Key findings of the study was public transportation is more popular and has higher utilities than private automobiles. Hence, the concerned authorities in developing countries like Bangladesh should allocate more resources for the development of public transportation.

## **2.9 Previous Applications of Trip chain & SE Modeling**

The majority of these studies have focused on socio-economic factors contributing to the number of stops within a trip chain, such as sex (Strathman et al. 1995; Strathman et al. 1994), age (Bhat, 1997; McGuckin et al. 2005; Schmöcker et al. 2010), income per month (Adler et al. 1979; Hensher et al. 2000), number of children (Hensher et al. 2000; Noland and Thomas, 2007). Other researchers have focused on the effects of technology advancements (Strathman et al. 1994) and Trip-specific features such as trip distance have been examined by Schmöcker et al. (2010), length of travel time and cost was analyzed by Bhat (1997) and parking availability along with day of the trip was observed by Primerano et al (2008). Bhat

(2015) developed a generalized heterogeneous data model to integrate residential location choice and travel behavior. Garikapati et al. (2016) studied the travel behavior of various age groups in north America. Habib and Weiss (2014) evaluated mode choice preference structures and latent modal captivity.

Modern life is becoming busier and has lack of free time that makes the peoples' trip chaining behavior more complex (Currie and Delbosc, 2011). Women trip chain is more complex and varied than man because of their multipurpose work including employment, home, baby caring, the elderly or other persons in need (McDonald, 1999). To fulfill the task in limited time budget leads to the growing tendency of chaining more trips in home - home or home - work trip chains, and the origin and destination of the trips can be both home or either home or working place (McGuckin and Nakamoto 2004; Kitamura and Susilo 2006). The ability to do multiple activities in a trip chain is more convenient and useful than a single stop simple chain (Hensher et al. 2000). Trip chaining behavior also increases individual transport usage such as car and thus increases the congestion and urban peak hours (Ye et al. 2007; Habib et al. 2009; Yun et al. 2014).

SEM was adopted in several fields of research and generalized by Joreskog and Wiley (Joreskog 1973; Wiley 1973). Application of SEM in travel behavior research initiates the analysis of complex causal relationship among individual's travel decisions. Travel behavior investigators applied SEM in their research in order to analyze complex causal relationship among travel-related variables, such as trip frequency, travel time or travel distance, activity duration, etc. Kitamura et al. (1992) and Golob et al. (1994) are the first known application of SEM to joint activity duration and travel time data. Kitamura (1996) gave an overview that includes discussions of the role of SEM in activity and time-use modeling. Lu and Pas (1997) revealed in home activities, out-of-home activities (by type), and travel (measured various ways), conditional on socioeconomic variables by SEM.

Golob and McNally (1997) presented an SEM of the interaction of household heads in activity and travel demand, with data from Portland. Activities are divided into three types, and SEM results are compared using maximum likelihood (ML) and generalized least squares (GLS) estimation methods. They conclude that GLS methods should be used to estimate SEM when it is applied to activity participation data.

Fuji and Kitamura (2000) studied the latent demand effects of the opening of new freeways. The authors used an SEM to determine the effects of commute duration and scheduling variables on after work discretionary activities and their trips by using data for Osaka-Kobe Region of Japan. Golob (2000) estimated a joint model of work and non-work activity duration using Portland data. Kuppam and Pendyala (2000) presented three SE models estimated by GLS using data from Washington, DC. The models concentrated on relationships between: activity duration and trip generation, durations of in-home and out-of-home activities, and activity frequency and trip chain generation. Simma and Axhausen (2001) developed an SEM that captured relationships between male and female heads of household with regard to activity and travel demands. The dependent variables included car ownership, distances traveled by males and females, and male and female trips by two types of activities using data from the upper Austria. Meka and Pendyala (2003) investigated the interaction between two adults in one household in their travel and activity time allocation by SEM using Southeast Florida data.

## CHAPTER 3

### METHODOLOGY

#### 3.1 Introduction

This chapter represents the research approach used in this study; research design, questionnaire survey, field survey schedule and location and questionnaire itself. In-person survey method has been adopted for research and analysis purpose.

#### 3.2 Research Design

A two-step methodology was adopted for this study. The first step was data collection approach incorporating purpose built questionnaire survey. The questionnaire contains three parts. The first part was about the respondents' socio-economic information. The second part involved information about trip chain of work related days and non-work related days and final part involved questions about trip characteristics. The respondents were asked to fill out the questionnaire at fourteen different locations in Dhaka city. Respondents were asked to rate their individual opinion to the questionnaires. This data collection method was used to extract the views of the passengers towards different attributes related to mode choice. Second step of this methodology was to develop SE models. For each empirical model, the process of model development follows the approach of trial and error in terms of shuffling various exogenous, endogenous and latent variables as well as observing overall goodness of fit of them. For testing parameter estimation a two-tailed t-test with a critical value of 1.96 for 95% confidence level is considered. In this study STATA 13 software is used for modeling.

A total of 1000 questionnaires were completed from the work trip makers. The interviews were conducted in March-April 2016 and the survey time was between 9.00 am to 4.00 pm.

### **3.3 Sample**

SEM is a large sample technique (usually sample size > 200) (Lei et al. 2007). One of the strengths of SEM is its flexibility, which permits examination of complex associations of various types of data (e.g. categorical, dimensional, censored, count variables), and comparisons across alternative models. However, general guidelines and requirements are difficult to develop because of these features of SEM (MacCallum et al. 1999). Despite this, various rules of thumb have been practiced. Boomsma (1982, 1985) adopted a minimum sample size of 100 or 200 while Bentler and Chou (1987) approached 5 or 10 observations per estimated parameter, and 10 cases per variable (Nunnally, 1967). Model characteristics such as the level of communality across the variables, sample size, and degree of factor determinacy affect the accuracy of the parameter estimates and model fit statistics, which raises doubts about applying sample size rules of thumb to a specific SEM (MacCallum et al. 1999). The sample size for this research was 978, which is adequate.

### **3.4 Survey Locations and Schedule**

The locations were chosen because those roads carry mixed modes. Those locations contain a large number of educational institutions, offices, business centres, shopping malls and those are very busy road with lots of cars, buses, rickshaws and other modes of travel. Many office going people were found in the places. Survey Schedule and Locations are shown at table 3:

**Table 3: Field Survey Locations and Schedule**

Sl. No.	Date	Time	Location of Survey
01.	04/03/2016	10.00 am	Beside Orchard point, Anwar Khan Modern Medical College and Mirpur Road
02.	04/03/2016	12.00 pm	Beside Nilkhet Signal
03.	05/03/2016	11.00 am	Jigatola Bus Stand
04.	05/03/2016	12.30 am	Beside keari plaza Dhanmondi-15
05.	06/03/2016	10.30 am	Beside Panthapath Signal
06.	06/03/2016	12.30 pm	Beside Wasa Bhaban
07.	06/03/2016	2.00 pm	Beside Ananda Cinema Hall
08.	08/03/2016	10.15 am	Kalabagan Bus Stand
09.	08/03/2016	12.00 pm	Shukrabad/ Dhanmondi 32 number
10.	10/03/2016	9.30 am	Beside Mohammadpur Bus Stand
11.	10/03/2016	11.45 am	Beside Shyamoli Cinema Hall
12.	12/03/2016	9.30 am	Beside Rapa Plaza Shopping Mall
13.	12/03/2016	11.10 am	Beside Asad gate Signal
14.	09/04/2016	10.00 am	Beside Gulshan 2 Circle

### 3.5 Questionnaire Survey

There were 20 questions in the questionnaire which was based on users' trip chain, mode choice, income level, travel time, and comfort level etc. The field survey locations and schedule are given in table 3. These are very busy locations. A large number of people make their trips through these locations either to work or from work or any other purposes. Most of the locations are part of present Dhaka North City Corporation (DNCC). However few locations were also chosen from Dhaka South City Corporation (DSCC) for this survey.



### **3.6 Questionnaire**

The questionnaire has five parts:

First part of the questionnaire is demographic information of passengers. This part consists of questions regarding to respondents' sex, age, occupation, educational qualification, marital status, information of family and availability of motorized vehicle etc.

Second part of the questionnaire is related to work characteristic. This part consists of questions regarding to respondents' family monthly income, per day working hour, parking availability at work place etc.

Third part of the questionnaire is about trip characteristics. This part consists of questions regarding to respondents' waiting time for a particular mode, in vehicle travel time, distance of trip, modal change to reach destination etc.

Fourth part of the questionnaire is on trip chain of the respondents. Trip chain was divided into two types: firstly for working day and the other is for non-working day.

Fifth and the last part of the questionnaire is the quality of service. This part consists of questions regarding respondents' travel mode, comfort level, monthly travel expenditure etc.

Questionnaires of the survey are shown at Appendix B.

### **3.7 Respondents**

Respondents were in the range of age between 20 to 60 years who live in Dhaka city and have the experience of using different modes. The age range was chosen because people in these ages have a routine commute travel behavior and probably have taken usually same mode as their primary mode of choice. The respondents were asked to fill up the questionnaire at the site. Overall data analysis has been shown in chapter four. Using these data models were developed to find the best model. Pictorial views of field survey at various locations are shown at Appendix A.

## CHAPTER 4

### DATA ANALYSIS

#### 4.1 Introduction

In this study, a total of 1000 trip makers were interviewed at 14 different locations in Dhaka City. Due to incompleteness of data 978 were taken in to consideration for analysis. Data analysis was done by excel firstly. A series of models are developed to identify the relationship of mode choice and trip chaining for work trips in Dhaka city. The target is to reveal the variables that influence mode choice and trip chaining. At the end, all the proposed models are compared and the optimal one is found out. The optimal model is the most representative one of the actual scenario. In this study STATA 13 software is used for modeling. STATA 13 uses ML (maximum likelihood) estimate method among the various parameter estimation methods. To cope with complexity of SEM more than one model should be introduced to define the goodness of fit of the models. Standardized Root Mean Squared Residual (SRMR), Root Mean Squared Error of Approximation (RMSEA), Tucker-Lewis Index (TLI) and Comparative Fit Index (CFI) are some measures that are used to define goodness of fit. According to Steiger (1990) a RMSEA value of 0.05 or less designates very good fit and a value below 0.10 designates good fit. Browne and Cudeck (1993) introduce that value of 0.08 or less is always reasonable. A value of SRMR less than .10 indicates a good fit of the data in Empirical SEM models (Lance et al, 2000). CFI values range between 0.0 and 1.0 with values closer to 1.0 indicating a good fit (Hooper et al. 2008)

## 4.2 Demographic Information

General information of the respondents are given at table 4.1

**Table 4.1 General information of respondents**

Features	Statistics
Gender	Male (96%), Female (4%)
Marital status	Married (71%), Single (29%)
Age	20~30 Years old (30%), 31~40 Years old (43%), Above 40 years old (27%),
Educational qualification	Doctorate (1%), Graduate (63%), Elementary (27%), Below elementary ((7%), no education (2%)
Number of household children	None (35%), One (32%), Two (28%), Three (4%), Above three (1%)
Number of household adults	One (8%), Two (42%), Three (25%), Above three (26%)
Number of family members	One (6%), Two (6%), Three (24%), Four (30%), Five or more (34%)
Occupation	Service holder (73%), Business (23%), Other (4%)
Working hour per day	3~5 (0%), 5~7 (5%), 7~9 (55%), above 9 (40%),
Monthly family income	5000~10000 Tk. (1%), 10000~20000 Tk. (20%), 20000~40000 Tk. (43%), >400000 Tk. (36%)
Number of household motorized vehicle	None (69%), One (26%), Two (5%)
Monthly household travel cost	<500 Tk (9%), 500~2000 Tk. (19%), 3000~5000 Tk. (38%), 6000~10000 Tk. (23%), > 10000 Tk. (11%)

### 4.2.1 Gender

In our country female workers are comparatively less than male workers in city except at garment sector. Moreover during survey only 4% female workers have participated.

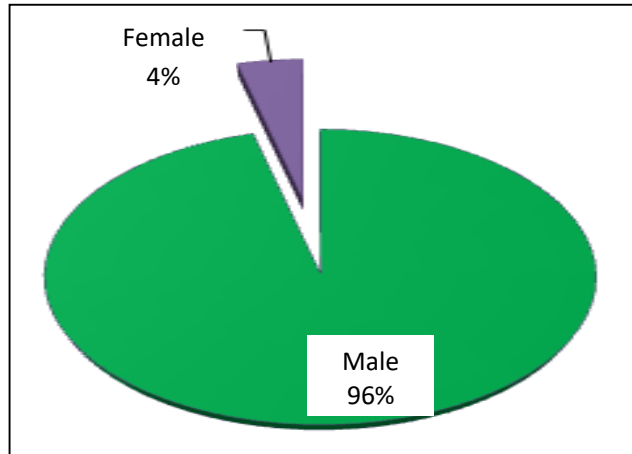

Figure 4.1: Gender status of respondents

### 4.2.2 Occupation

Figure 4.2 shows that 73% of the respondents were service holder, 23% were businessmen and 4 % were from other occupations. This shows that maximum respondents were service holders.

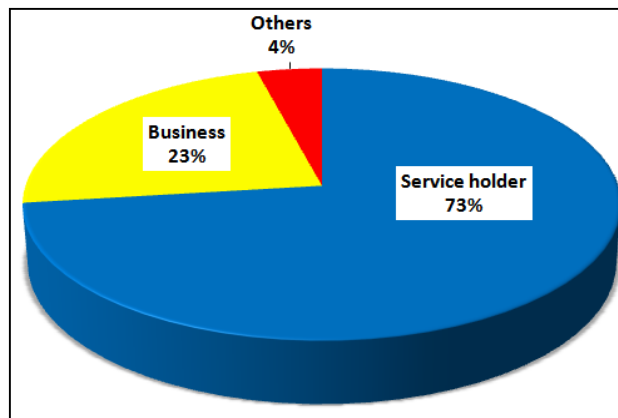

Figure 4.2: Occupation of the respondents

### 4.2.3 Marital Status

Figure 4.3 shows that 71% of the respondents were married and 29% respondents were single.

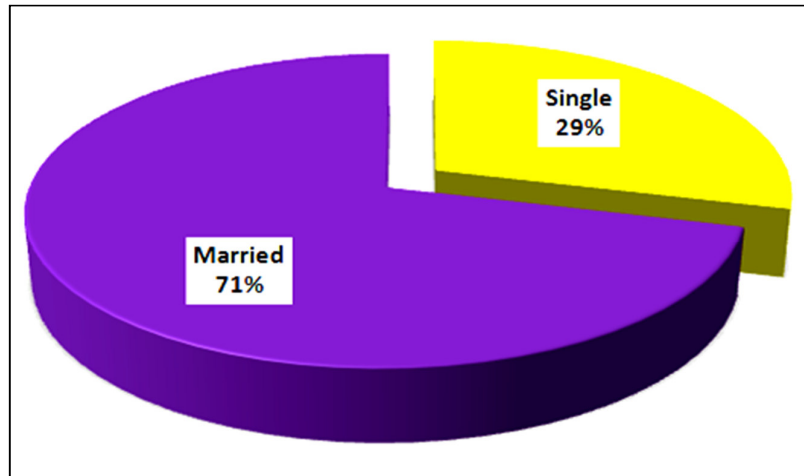

Figure 4.3: Marital status of respondents

### 4.2.4 Educational Qualification

Figure 4.4 shows that 63% of the respondents were graduate, 27% were elementary/diploma/intermediate, 7% were below elementary, 2% had no education and only 1% respondents' had doctoral degree.

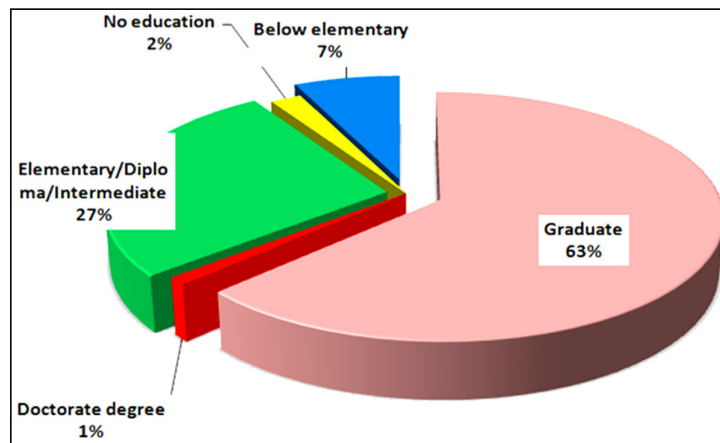

Figure 4.4: Educational qualification of respondents

#### 4.2.5 Age

Young people like to travel by public transport with difficulties whereas aged people prefer to travel with independent/hired transport in Dhaka city. Figure 4.5 shows that 43% of the respondents' age were within the range of 31-40 years, 30 % were within 20 -30 years and 27% respondents were within the range of 41-60 years.

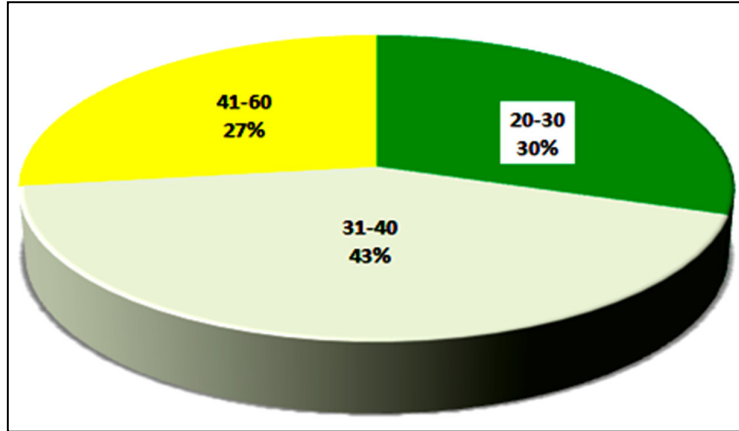

Figure 4.5: Age of respondents

#### 4.2.6 Number of Household Children

Figure 4.6 shows that 49% of the respondents had one child, 43% had two children, 6% had three children and 2% of the respondents' had more than three children. From the survey, it has been seen that most of the respondents have either one or two children.

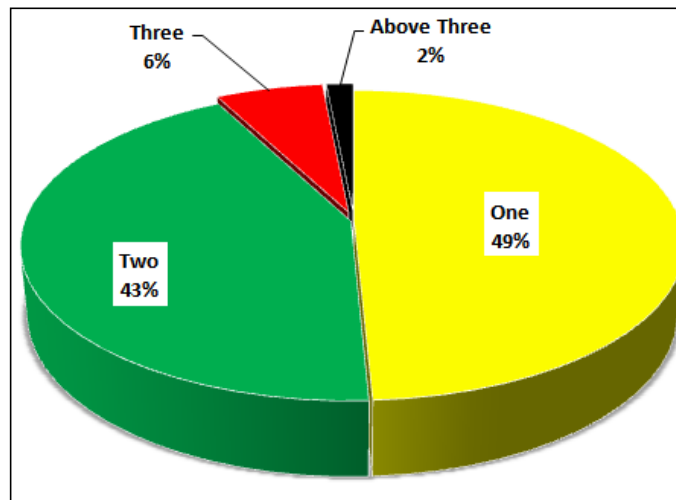

Figure 4.6: Number of household children

#### 4.2.7 Number of Household Adults

Number of household adults determines the number of work trips that are produced from a household trip. Figure 4.7 shows that 41% of the respondents had two household adults, 26% had more than three, 25% had three and 8% had only one household adult in the family.

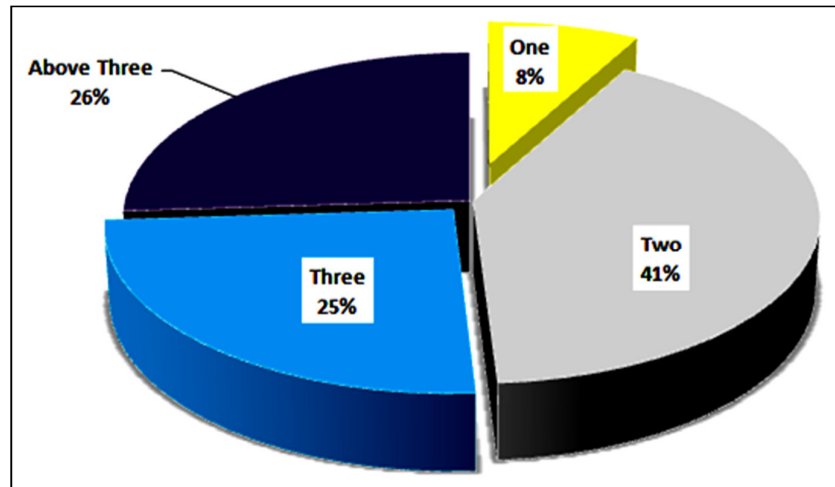

Figure 4.7: Number of household adults

#### 4.2.8 Number of Family Members

Figure 4.8 shows that 33% of the respondents had five or more family members, 31% had four, 24% had three and 6% respondents had two/one family members.

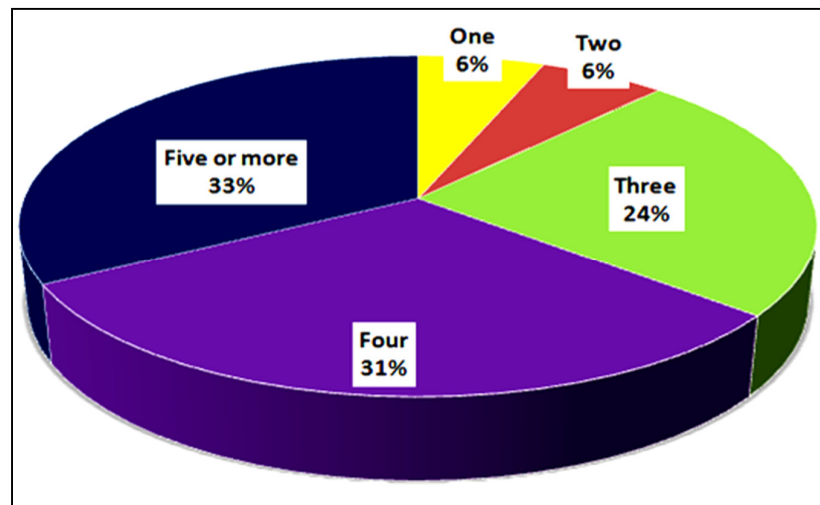

Figure 4.8: Number of family member

#### 4.2.9 Family Monthly Income

Family monthly income is one of the main factors of choosing mode of travel. Figure 4.9 shows that 43% of the respondents' monthly family income was within the range of 20000-40000 taka, and 36%, 20% and 1% of the respondents' monthly family income was 40,000 tk, 10,000-20,000 tk and 5,000-10,000 tk respectively.

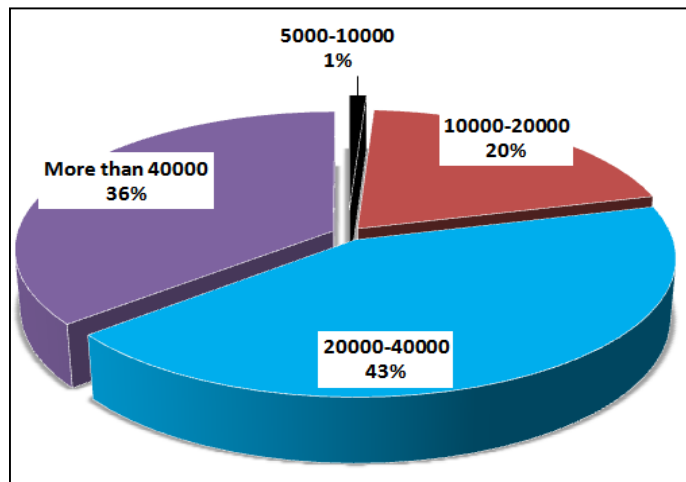

Figure 4.9: Monthly family income of respondents

#### 4.2.10 Working Hour Per Day

Figure 4.10 shows that 55% of the respondents' working hour was within 7-9 hours, 40% and 5% were above 9 hours and within 5-7 hours in a day respectively.

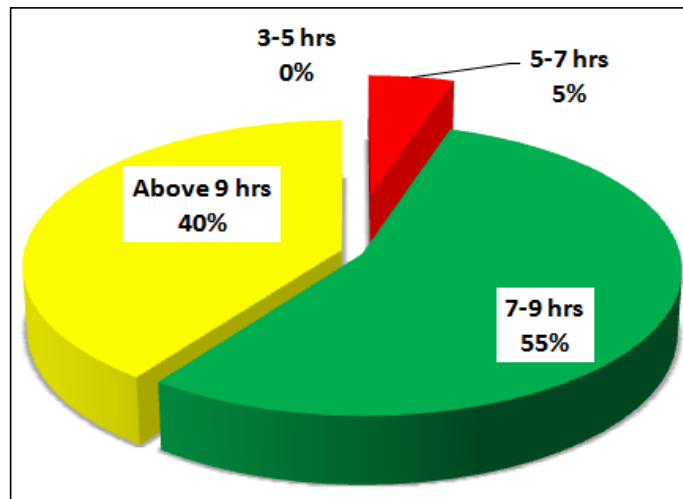

Figure 4.10: Working hour per day



#### 4.2.11 Number of Household Motorized Vehicle

Figure 4.11 shows that 69% of the respondents had no household motorized vehicle, 26% had only one household motorized vehicle and 5% had two household motorized vehicles.

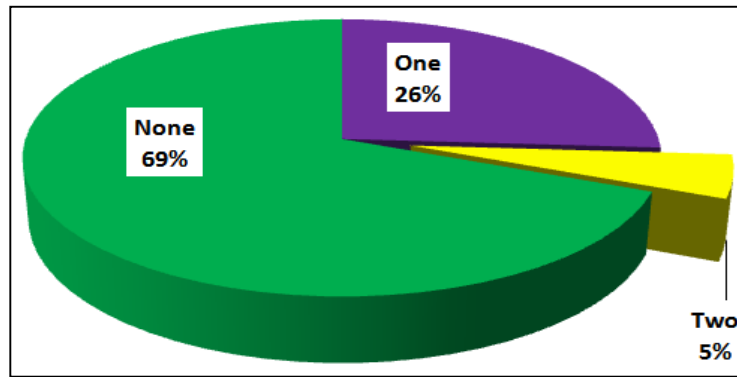

Figure 4.11: Number of household motorized vehicle

#### 4.2.12 Monthly Household Travel Expenditure

Figure 4.12 shows that 38% of the respondents' monthly household travel expenditure is within the range of 2000-5000 taka and 23%, 19%, 11% and 9% respondents' monthly household travel expenditures is 5000-10000 taka, 500-2000 taka, above 10000 taka and less than 500 taka respectively. Household travel expenditure mainly depends on the household income. Maximum respondents' monthly household travel expenditure is within the range of 2000-5000 tk.

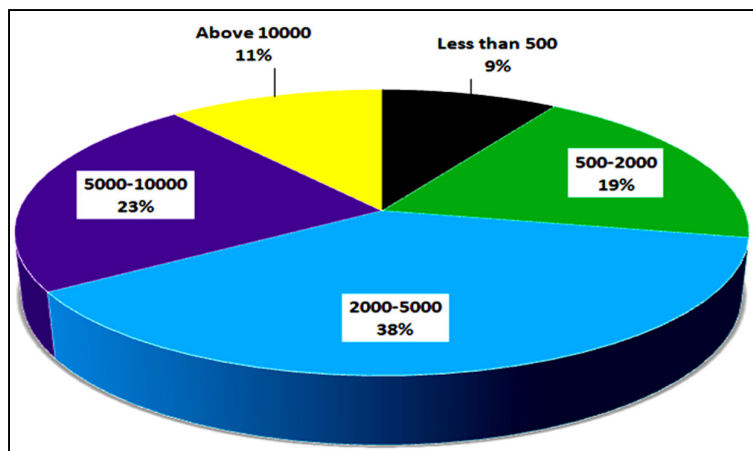

Figure 4.12: Monthly household travel expenditure

### 4.3 Parking Availability

Figure 4.13 shows that 50% of working place had no parking facility, 25% had good, 20% had moderate, 3% had very good and 2% had excellent parking facility.

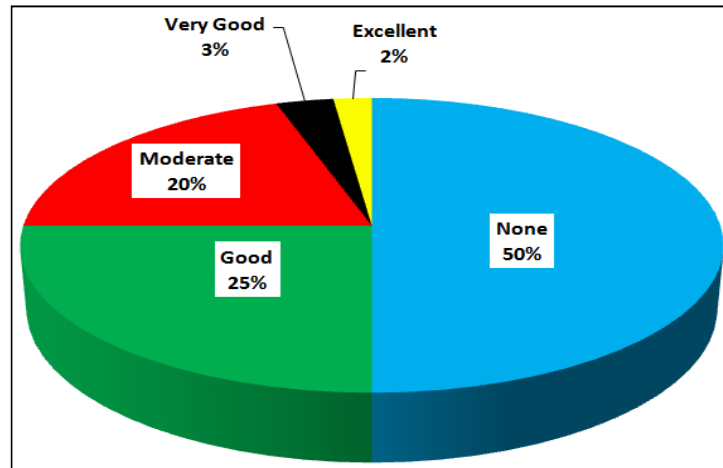

Figure 4.13: Parking availability at work place

### 4.4 Trip Distance

Distance from home to work is very important factor for any trip. Figure 4.14 shows that 36 % of the respondents' trip distance was within 1-3 km and 26%, 24% and 14% of the respondents' trip distance was within 3-5 km, above 5 km and less than 1 km respectively.

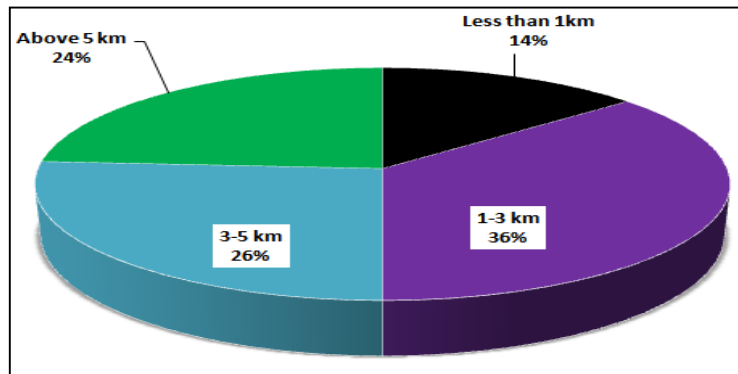

Figure 4.14: Home to work trip distance of respondents

#### 4.5 Change of Mode

Figure 4.15 shows that 79% of the respondents didn't change their mode to reach their destination. 18%, 2% and 1% of the respondents changed their mode 1 time, 2 times and 3 times respectively. It indicates that most of people do not like to change their mode during the work trip.

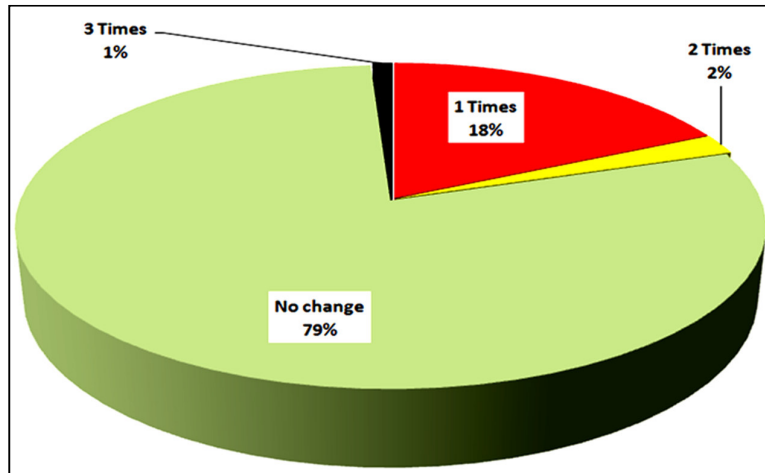

Figure 4.15: Percentage of changing mode

#### 4.6 Trip Chain of Work Related Days

Eight categories of trip chains have been considered in this research:

- i. Simple home to work ; work to home h-w-(-w-)-h trip
- ii. One non-work from home to work and one non-work stop from work to home h-nw-w-(-w-)-nw-h trip
- iii. No non-work from home to work but one non-work stop from work to home h-w(-w-)-nw-h
- iv. No non-work from home to work but two non-work stop from work to home h-w(-w-)nw-nw-h
- v. No non-work from home to work but more than two non-work stop from work to home h-w(-w-)-nw-nw-(-nw-)-h

- vi. One non-work from home to work and no non-work stop from work to home  
h-nw-w(-w-)-h
- vii. More than one non-work from home to work and one non-work stop from  
work to home h-nw-(-nw-)-w(-w-)-h
- viii. Others (multiple non-work stops from home to work journey and from work to  
home journey not covered in trip chain pattern 1-7)

Table 4.2 shows the number and type of trip chain the respondents made in work related days in a month. Respondents made above 15 days h-w(-w-)-h trip chain 829 times and h-nw-w(-w-)-h trip chain 18 times within a month. Respondents also made 1 to 5 days h-nw-w(-w-)-nw-h trip chain 158 times, h-w(-w-)-nw-h trip chain 204 times, h-w(-w-)-nw-nw-h trip chain 27 times, h-w(-w-)-nw-nw-(-nw-)-h trip chain 11 times, and others made trip chain 32 times within a month. Very few respondents made h-nw-(-nw-)-w(-w-)-h trip chain within a month.

**Table 4.2 Trip chain in work related days**

Trip Chain	Number of trip chain made by respondents				
	1 to 5 days	6 to 10 days	11 to 15 days	Above 15 days	Percentage
1. h-w(-w-)-h	20	30	41	829	50%
2. h-nw-w(-w-)-nw-h	158	56	19	32	14%
3. h-w(-w-)-nw-h	204	168	86	28	26%
4. h-w(-w-)-nw-nw-h	27	3	6		2%
5. h-w(-w-)-nw-nw-(-nw-)-h	11	1	1		1%
6. h-nw-w(-w-)-h	15	3		18	2%
7. h-nw-(-nw-)-w(-w-)-h		1	1		0
8. Others (multiple non-work stops from home to work journey and from work to home journey not covered in trip chain pattern 1-7)	32	16	5	30	5%

#### 4.6.1 Percentage of Trip Chain of Work Related Days

Figure 4.16 shows that majority (50%) of the respondents said that they made h-w(-w)-h trip chain during work related days within a month. 26% respondents made h-w(-w)-nw-h trip chain, 14% made h-nw-w(-w)-nw-h trip chain, 2% made h-w(-w)-nw-nw-h trip chain within a month. Respondents also made h-w(-w)-nw-nw-(-nw)-h, h-nw-w(-w)-h, h-nw-(-nw)-w(-w)-h and others trip chain during work related days within a month as 1%, 2%, 0% and 5% people respectively.

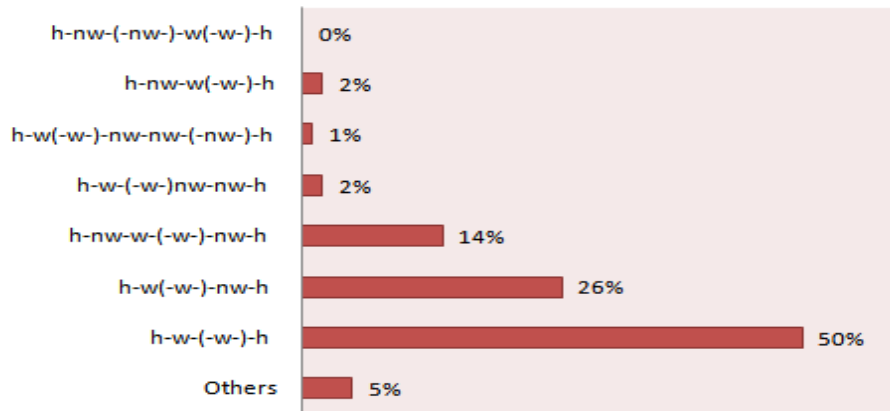

Figure 4.16: Percentage of trip chain in work related day

#### 4.7 Trip Chain of Non-work related day

##### 4.7.1 Trip Chain of Home-Non-work Home

Trip chain involves only one non-work activity : **h-nw-h**. Figure 4.17 shows that 67% of the respondents had 1-5 times h-nw-h trip chain of non-work related days within a month. 25% respondents had none, 6% had 6-10 times and 1% had 11-15 or more than 15 times h-nw-h trip chain in a month respectively.

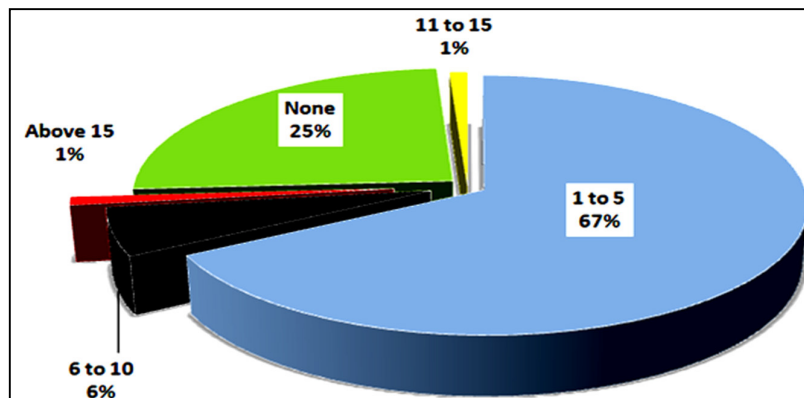

Figure 4.17: h-nw-h trip chain within a month

#### 4.7.2 Trip Chain of Home - Non work – Non work - Home

Trip chain involves more than one non-work activity: **h-nw-(-nw)-h**. Figure 4.18 shows that 51% of the respondents had 1-5 times h-nw-(-nw)-h trip chain within a month. 47% respondents had none and 1% had 6-10 or above 10 times h-nw-(-nw)-h trip chain respectively.

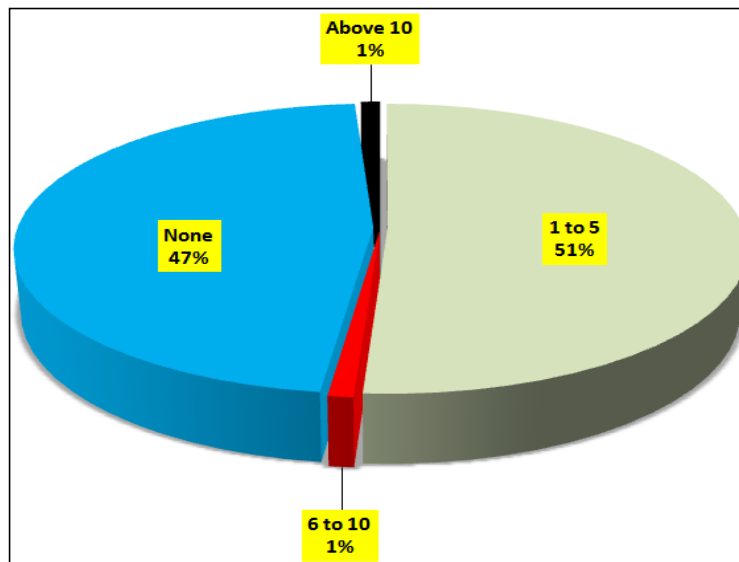

Figure 4.18: h-nw-(-nw)-h trip chain within a month

#### 4.8 Mode of Travel

Seven types of mode of travel have been considered in this research:

- i. Bus/Tempo
- ii. Three wheeler
- iii. Private car
- iv. Taxi
- v. Motor cycle
- vi. Bi-cycle/Rikshaw
- vii. Walk

Table 4.3 shows how many times respondents use a particular mode of travel within a month. Above 15 days respondents use bus/tempo as mode of travel 607 times, private car 114 times, motor cycle 121 times and walk 40 times within a month. Respondents use three wheeler 1 to 5 days as mode of travel 76 times, taxi 26 times, bi-cycle/rickshaw 115 times within a month.

**Table 4.3 Mode of Travel within a month**

Mode of Travel	How many times within a month you use				
	1 to 5 days	6 to 10 days	11 to 15 days	Above 15 days	Percentage
Bus/Tempo	29	17	23	607	46%
Three wheeler	76	33	20	32	11%
Private car	3	2	3	114	8%
Taxi	26	5	1	3	2%
Motor cycle	4	2	8	121	9%
Bi-cycle/Rickshaw	115	63	24	85	19%
Walk	18	9	4	40	5%

#### 4.9 Percentage of Using Mode

Figure 4.19 shows the percentage of different types of mode used by the respondents. 46% of the respondents used bus/tempo as travel mode for their working trip. 19% respondents used Bi-cycle/rickshaw, 11% used three wheeler, 9% used Motor cycle, 8% used Private car, 5% Walked and 2% respondents used Taxi as travel mode for working trip.

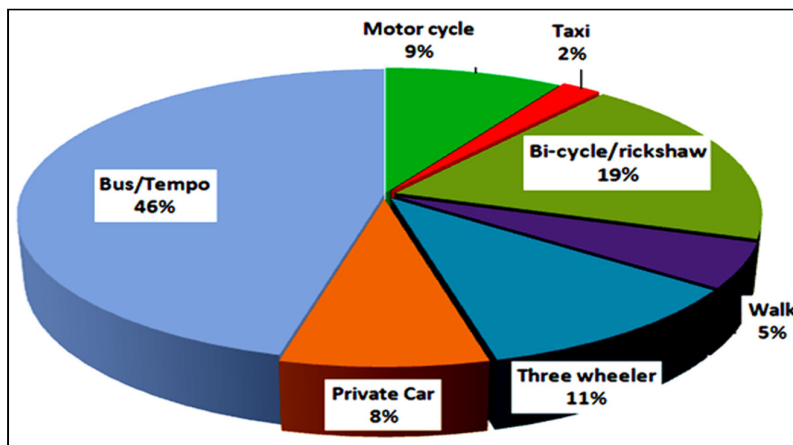

Figure 4.19: Mode of Travel use in a month

#### 4.10 Waiting Time

Figure 4.20 shows that 35% of the respondents had to wait 5-10 minutes for their mode of travel and 31%, 27% and 7% of the respondents had to wait less than 5 minutes, 10-15 minutes and more than 15 minutes respectively for their mode of transport.

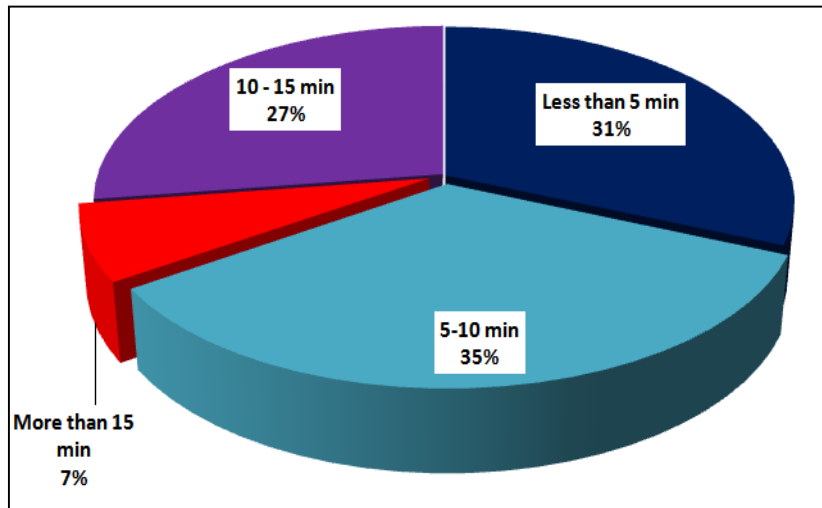

Figure 4.20: Waiting time of respondents

#### 4.11 Travel Time

Figure 4.21 shows that 36% of the respondents' travel time was 30 minutes and 33%, 15%, 13% and 3% of the respondents' travel time was 1 hour, 20 minutes, more than 1 hour and 10 minutes respectively.

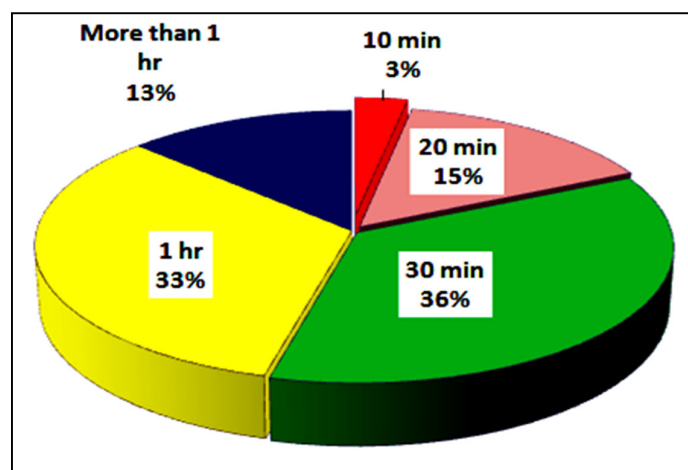

Figure 4.21: In vehicle travel time of respondents



#### 4.12 Comfort Level

Figure 4.22 shows that 49% of the respondents were uncomfortable with the trip, 42% were comfortable, 5% were very uncomfortable and only 4% respondents were very comfortable during their trip.

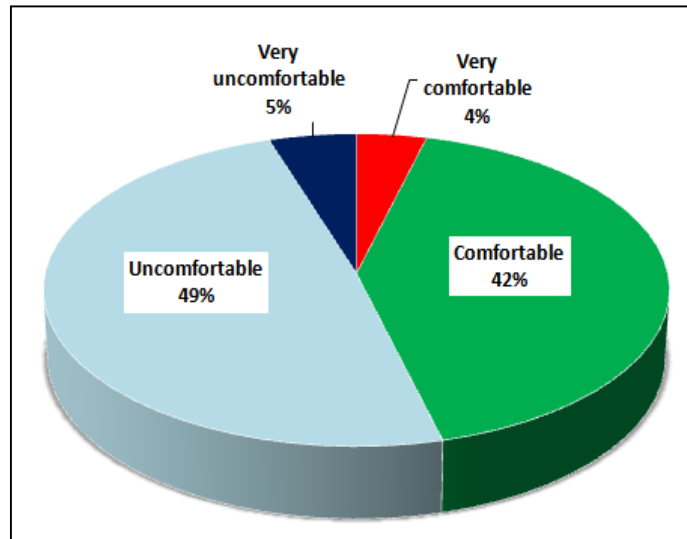

Figure 4.22: Comfort level of respondents

## CHAPTER 5

### MODELING AND RESULT ANALYSIS

#### 5.1 Introduction

Consideration of respondents' socio-economic conditions, travel behavior is vital in choice of travel mode for work trips in Dhaka city. It was revealed that the choice proportion of different mode of transport depends on various socio-economic and transport service factors, such as age, occupation, household size, income level, travel expenses, gender travel time and comfort etc.

#### 5.2 Development of Models and Result Analysis

A series of structural equation models are developed to find out the correlation between the mode choice attributes and effects on overall mode choice. The target is to identify which parameters are more important for choosing a mode. For each model, there is a shuffling of endogenous, exogenous and latent variables to examine models for better results. A two-tailed test is used for analyzing the parameters with a critical value of 1.64 for 95% confidence limit. At the end all the models are compared and optimal models are found out and they are most representative one of the actual scenario. However, some variables with z value less than the critical value are also reported and expecting that these parameters would have significant effect if the data set was larger.

Four different models are developed for revealing the relationships of different variables with mode choice. Some of the variables related with trip behaviors, some were with the trip chains at work related and non-work related days. Total 15 observed variables are used as exogenous and endogenous variables in different models and some latent variable are also introduced to get good models. Table 5.1 shows the variables that are used in developing different models. During development of all models we have used few common notations.

These are as follows:

$x$	indicates exogenous observed variables
$Y$	and $y$ indicates endogenous observed variables
$Z$	indicates CL of mode choice
$\eta$	indicates latent variables
$\rho$	indicates measurement errors in $y$
$\varepsilon$	indicates measurement errors in $Y$
$\zeta$	indicates errors in $\eta$
$\delta$	indicates errors in $Z$
$\varphi$	indicates parameters of the $y$ variables
$\lambda$	indicates parameters of the $Y$ variables
$\alpha$	indicates parameters of the $\eta$ variables when they influence $Y$ variables
$\gamma$	indicates parameters of $\eta$ variables when they influence $y$ variables
$\Gamma$	indicates parameters of the $c$ variables
$\lambda_0$	indicates constant values

### 5.2.1 Development of Model 1 (M1):

**Model 1** is developed without any latent variable. Two endogenous variables as “Time taken to reach destination, ( $Y_1$ )” and “Waiting time, ( $Y_2$ )” are used to construct model 1 (Figure 5.1). “Time taken to reach destination” describes trip characteristics. Trip chains constructed with seven exogenous variables (item 1-item 2; item 4-item 7; item 15; Table 5.1). Waiting time signifies mode specific features described by five exogenous variables (item 8-item 12; Table 5.1). The structure of M1 is shown in Figure 5.1. From the structure of M1, the following equation can be written-

$$Z = \lambda_0 + \lambda Y + \delta \dots\dots\dots (1)$$

Now, the used in equation (1) is –

$$Y = \Gamma X + \varepsilon \dots\dots\dots (2)$$

“Time to reach destination” is one of the important variables that influence mode choice positively because users always want to reach their destination as quick as possible. However, the result of model 1 (co-efficient value -0.097; Table 5.2) shows that “Time taken to reach destination” is an insignificant variable. Also, it influences passengers' mode choice negatively which does not match the actual case. Shortest travel time allows the respondent to arrive at work earliest. Nevertheless congestion characterizes common scenario of everyday life in Dhaka city especially for rush commuting hours. The results indicate that users are likely to select alternatives that allow them to reach at a lower cost and are not really influenced whether the alternative takes longer travel time or not. Furthermore, the results show some other inconsistencies such as “Parking availability”, “One non-work from home to work and one non-work stop from work to home trip”, “No non-work from home to work but more than two non-work stop from work to home trip” influences negatively (-0.12, -0.032, -0.047; Table 5.2). Waiting time influences mode choice negatively (-0.055; Table 5.2) which also does not match with the real scenario. “Travel by private car” and “Travel by motor cycle” influence “Waiting time” negatively (-0.2, -0.19; Table 5.2). Exogenous variables “Trip distance”, “Comfort level”. “Simple home to work; work to home trip”, and “No non work from home to work but one non-work stop from work to home trip” are significant and influence positively (0.59, 0.058, 0.046; Table 5.2). With some unconventionalities M1 has poor fit indices (CFI= 0.817, RMSEA= 0.066, SRMR= 0.051); M2 is developed.

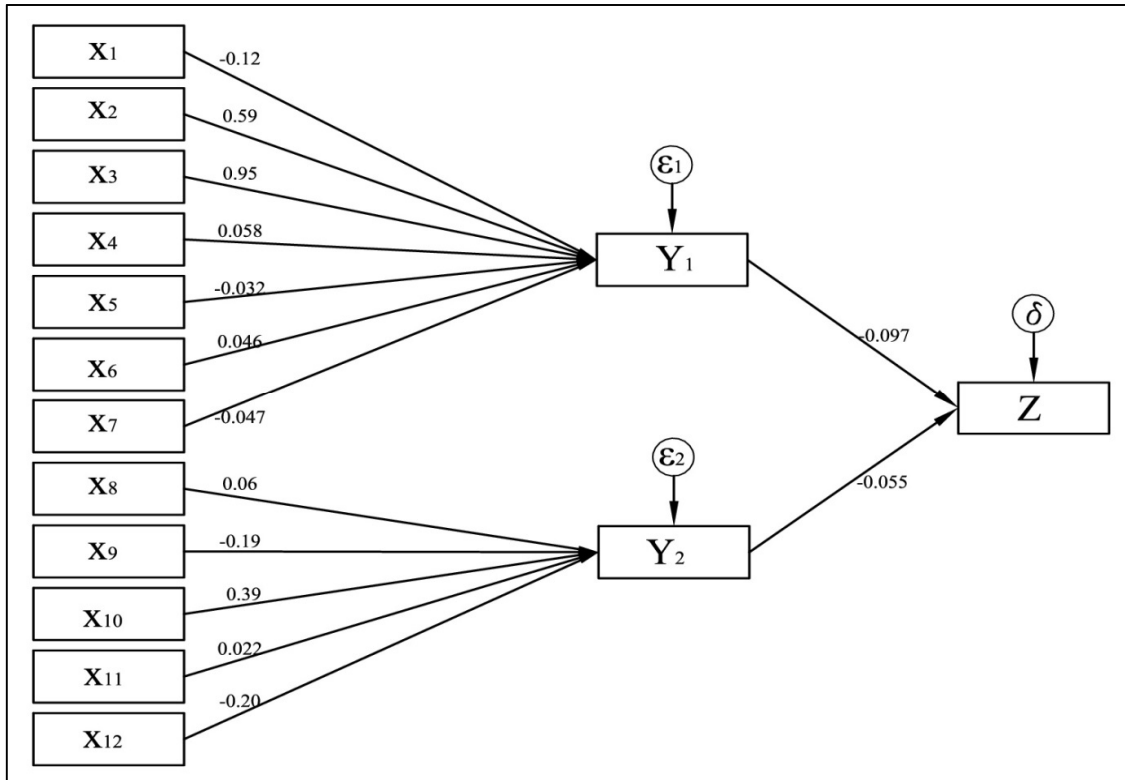

Figure 5.1: Path diagram of model 1

### 5.2.2 Development of Model 2 (M2):

**Model 2** has one latent variable introducing all variables by trip behavior ( $\eta$ ). Trip behavior ( $\eta$ ) is calibrated by three endogenous variables characterizing time and comfort of mode (item 13-item 15; Table 5.2). Ten exogenous variables (item 1-item 2; item 4-item 10; item 12; Table 5.2) are calibrated with the latent variable. The structure of M2 is shown in figure 5.2. From the structure of M2, the following equation can be written-

$$Z = \lambda_0 + \lambda Y + \delta \dots \dots \dots (3)$$

Where  $Y$  in eq. (3) symbolizes the three endogenous variables (item 13-item 15; Table 5.2)

$$Y = \alpha \eta + \epsilon \dots \dots \dots (4)$$

and  $\eta$  symbolizes the latent variable which is calibrated by the remaining ten exogenous variables (item 1-item 2; item 4-item 10; item 12; Table 5.2).

$$\eta = \frac{x - \varepsilon}{\gamma} \dots\dots\dots(5)$$

In this model change of mode is observed and it is seen that waiting time and time taken to reach destination influences change of mode positively (0.045, 0.91; Table 5.2) which is reasonable and match with the real scenario because waiting time and time taken to reach destination really effects a lot for changing of mode. However, comfort level of mode influences change of mode negatively (-0.041; Table 5.2) which is not expected because comfort is always preferable by the passengers especially for long distance. Model 2 results show some other irrelevancies with the real scenario. For example, Simple home to work; work to home, No non-work from home to work but more than two non-work stop from work to home, Travel by private car, Travel by motor cycle are negatively influenced trip behavior while parking availability, trip distance, one non-work from home to work and one non-work stop from work to home, no non work from home to work but one non-work stop from work to home, travel by bus/train/tempo, travel by bicycle/rickshaw influence trip behavior positively that is very much expected. With some irregularities M2 has good fit indices (CFI= 1.00, RMSEA= 0.000, SRMR= 0.012); M3 is developed.

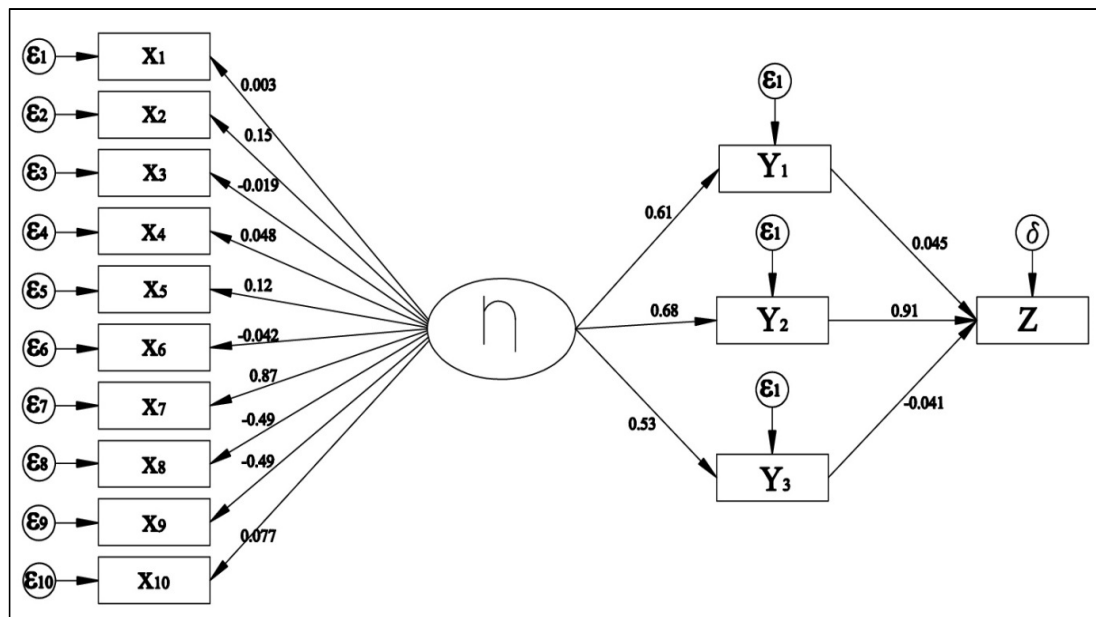

Figure 5.2: Path diagram of model 2

**5.2.3 Development of Model 3 (M3):**

**Model 3** introduces three latent variables obtained by splitting all the variables into three parts; Trip characteristics ( $\eta_1$ ), Trip chain of work related days ( $\eta_2$ ) and trip chain of non-work related days ( $\eta_3$ ). Trip characteristics is calibrated by three endogenous variables (item-1- item 3; Table 5.1) , Trip chain of work related days is calibrated by four endogenous variables (item 4-item 6; item 7; Table 5.1) and Trip chain of non-work related days is calibrated by nine endogenous variables (item 7- item 15). The structure of M3 is shown in figure 5.3. From the structure of M3, the following equation can be written-

$$y_{15} = \lambda_0 + \mu\eta + \varepsilon_{15} \dots\dots\dots (6)$$

In Equation (6), the latent variables are symbolized by  $\eta$  which are calibrated by the fourteen endogenous variables (item-1- item 14; Table 5.1).

$$\eta = \frac{y-\varepsilon}{\gamma} \dots\dots\dots (7)$$

In this model, one endogenous variable is introduced namely ‘No non-work from home to work but more than two non-work stop from work to home’ which is calibrated with both Trip chain of work related days ( $\eta_2$ ) and Trip chain of non-work related days ( $\eta_3$ ). Three latent variables connected with each other. The path connecting Trip characteristics ( $\eta_1$ ) and Trip chain of work related days ( $\eta_2$ ) has the parameter of 0.36 (Z value 2.67). The path connecting Trip characteristics ( $\eta_1$ ) and Trip chain of non-work related days ( $\eta_3$ ) has the parameter of 2.5 (Z value 1.68) and Trip chain of work related days ( $\eta_2$ ) and Trip chain of non-work related days ( $\eta_3$ ) has the parameter of .49 (Z value 1.67). These parameters indicate that latent variables are correlated with each other strongly which is rational. Among the three latent variables trip characteristics ( $\eta_1$ ) influences parking availability negatively

(-.12; Table 5.2) and trip distance and change of mode positively (.59 and .99; Table 5.2). Trip chain of work related days ( $\eta_2$ ) influences Simple home to work; work to home and No non work from home to work but one non-work stop from work to home positively (.058, .046; Table 5.2) and One non-work from home to work and one non-work stop from work to home negatively (-.032; Table 5.2) while trip chain of non-work related days ( $\eta_3$ ) influences nine endogenous variables. Trip chain of work related days ( $\eta_2$ ) influences ‘No non-work stop/trip from home to work but more than two non-work stop from work to home’ negatively (-.06; Table 5.2) and Trip chain of non-work related days ( $\eta_3$ ) influences ‘No non-work from home to work but more than two non-work stop from work to home’ positively (.039; Table 5.2). From the results of model 3, it is seen that Trip chain of non-work related days influence comfort level positively which is anticipated. Similarly Trip chain of non-work related days influence waiting time negatively is not expected at all because on those days passengers prefer to make trip in short period. With some anomalies fit indices of M3 are within range (CFI= 1.00, RMSEA= 0.000, SRMR= 0.000), indicating a good model.

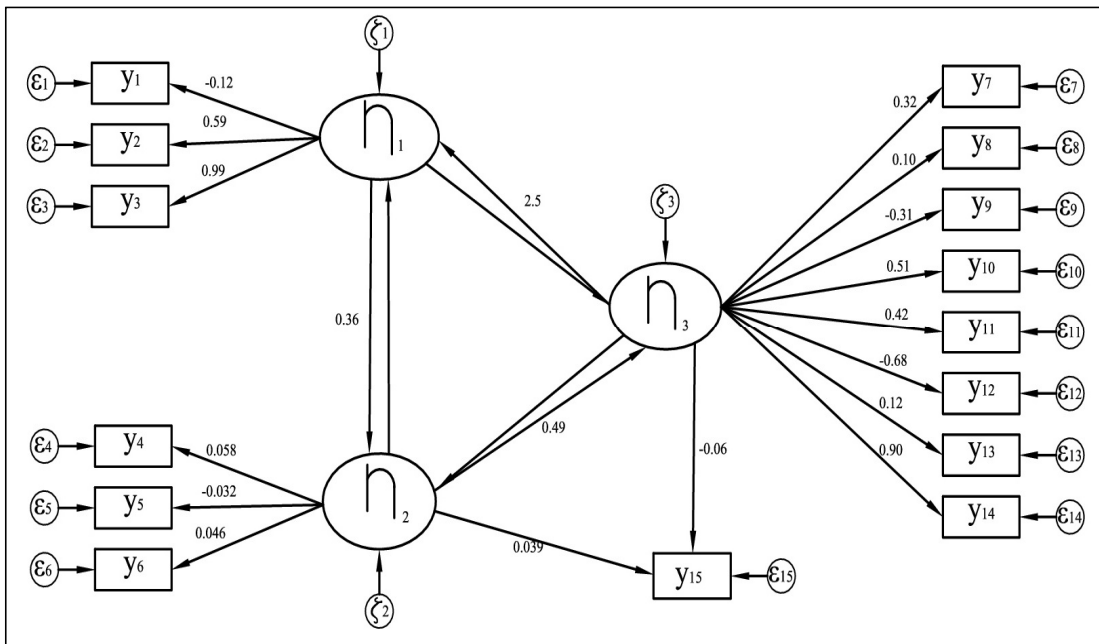

Figure 5.3: Path diagram of model 3



**5.2.4 Development of Model 4 (M4):**

In quest of best model, model 4 has been developed, where two latent variables are introduced. Trip behavior ( $\eta_1$ ) is calibrated by seven endogenous variables (item 1- item 7; Table 5.1) and Trip chain ( $\eta_2$ ) is calibrated by seven endogenous variables (item 8-item 10; item 12-item 15; Table 5.1). Both of the latent variables ‘Trip behavior’ and ‘Trip chain’ significantly influence each other.

The structure of M4 is shown in figure 5.4. From the structure of M4, the following equation can be written-

$$y_{14} = \lambda_0 + \mu\eta + \varepsilon_{14} \dots\dots\dots (8)$$

In Equation (8), the latent variables are symbolized by  $\eta$  which are calibrated by the fourteen endogenous variables (item-1- item 10; item 12-item 15; Table 5.1).

$$\eta = \frac{y-\varepsilon}{\gamma} \dots\dots\dots (9)$$

Based on model fit indices model 4 can be considered as the best model. Endogenous variables parking availability, trip distance, change of mode to reach destination, simple home to work-work to home, one non-work from home to work and one non-work stop from work to home, no non work from home to work but one non-work stop from work to home, no non-work from home to work but more than two non-work stop from work to home; these endogenous variables have positive relation (0.69, 0.05, 0.94,0.024 , 0.01,0.032, 0.18; Table 5.2) with trip behavior which represents the actual scenario while other seven endogenous variables(item 8-item 10; item 12-item 15; Table 5.1) have positive relation with the latent variable ‘Trip chain’ which is reasonable. Two latent variables,  $\eta_1$  and  $\eta_2$  are connected with each other and the correlation between two latent variables is strong and significant with coefficient of 2.5.

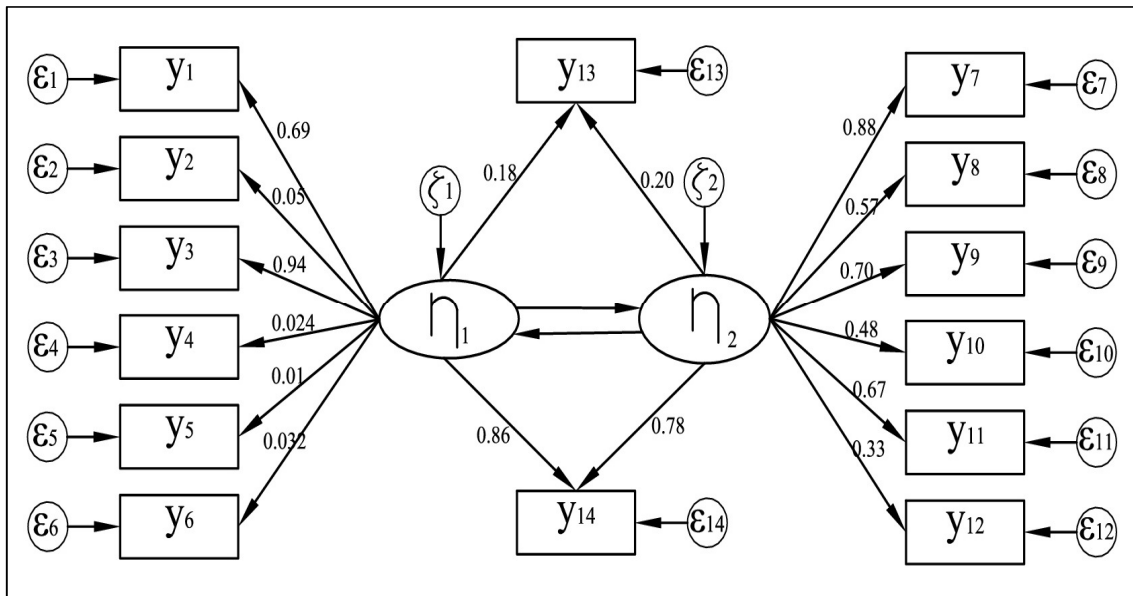

Figure 5.4: Path diagram of model 4

Fit indices of M4 are CFI= 1.00, RMSEA= 0.000, SRMR= 0.000. From the results, it can be seen that all of the fitting indicators are within the recommended range. Therefore, the model M4 has a good fit. So overall, model 4 can be considered as the best model among the four models.

**Table 5.1 Attributes and their input in the models**

Item no	Description	Model 1		Model 2		Model 3		Model 4	
		Type	Notation	Type	Notation	Type	Notation	Type	Notation
1	Parking availability	Ex.	X1	Ex.	X1	En.	y 1	En.	y1
2	Trip distance	Ex.	X2	Ex.	X2	En.	y 2	En.	y 2
3	Change of mode	P.	Z	P.	Z	En.	y 3	En.	y 3
4	Simple home to work-work to home trip	Ex.	X4	Ex.	X3	En.	y 4	En.	y 4
5	One non-work from home to work and one non-work stop from work to home trip	Ex.	X5	Ex.	X4	En.	y 5	En.	y 5
6	No non-work from home to work but one non-work stop from work to home trip	Ex.	X6	Ex.	X5	Ex.	y 6	En.	y 6
7	No non-work from home to work but more than two non-work stop from work to home trip	Ex.	X7	Ex.	X6	En.	y15	En.	y 13
8	Travel by bus/tempo	Ex.	X10	Ex.	X7	En.	y 14	En.	y 7
9	Travel by bicycle/rickshaw	Ex.	X8	Ex.	X10	En.	y 10	En.	y 10
10	Travel by private car	Ex.	X12	Ex.	X8	En.	y 13	En.	y 8
11	Travel by taxi	Ex.	X11	N/A	N/A	En.	y 12	N/A	N/A
12	Travel by motor cycle	Ex.	X9	Ex.	X9	En.	y11	En.	y 9
13	Waiting time at the station	En.	Y2	En.	Y1	En.	y 9	En.	y 11
14	Time taken to reach the destination	En.	Y1	En.	Y2	En.	y 8	En.	y 12
15	Comfort level of the mode	Ex.	X3	En.	Y3	En.	y 7	En.	y 14
16	Trip Characteristics	N/A	N/A	N/A	N/A	Lt.	$\eta$ 1	N/A	N/A
17	Trip chain of work related days	N/A	N/A	N/A	N/A	Lt.	$\eta$ 2	N/A	N/A
18	Trip chain of non-work related days	N/A	N/A	N/A	N/A	Lt.	$\eta$ 3	N/A	N/A
19	Trip behavior	N/A	N/A	Lt.	$\eta$	N/A	N/A	Lt.	$\eta$ 1
20	Trip chain	N/A	N/A	N/A	N/A	N/A	N/A	Lt.	$\eta$ 2

Ex. = Exogenous variables; En. = Endogenous variables; Lt. =Latent variables; N/A= Not applied in this model; P. = Overall Perceived variable

**Table 5.2 Estimated parameters for different models**

<b>Observed Variables</b>	<b>Model 1 estimates</b>	<b>Model 2 estimates</b>	<b>Model 3 estimates</b>	<b>Model 4 estimates</b>
Parking availability	-12(0.00)	.0032(.650)	-12(.169)	.69(.745)
Trip distance	.59(0.00)	.15(.001)	<i>0.59(.244)</i>	.05(0.00)
Change of mode	<i>.095(0.00)</i>	.98(.224)	0.99(.198)	.94(.177)
Simple home to work-work to home trip	<i>.058(0.00)</i>	-0.19(.580)	0.058(.130)	.024(.096)
One non-work from home to work and one non-work stop from work to home trip	-0.032(.204)	<i>.048(0.00)</i>	-0.032(.136)	<i>.01(.0125)</i>
No non-work from home to work but one non-work stop from work to home trip	<i>.046(.065)</i>	.12(0.00)	.0046(.194)	<i>.032(.003)</i>
No non-work from home to work but more than two non-work stop from work to home trip	-0.047(.060)	-0.042(0.00)	-0.06(0.00)	<i>.18(.004)</i>
			0.039(.306)	<i>.20(0.00)</i>
Travel by bus/tempo	.39(0.00)	.87(0.00)	.9(0.00)	.88(0.00)
Travel by bicycle/rickshaw	.06(.030)	<i>.077(0.00)</i>	<i>.51(0.00)</i>	<i>.48(0.00)</i>
Travel by private car	-0.2(0.00)	-0.49(0.00)	.12(0.00)	.57(0.00)
Travel by taxi	<i>.022(0.030)</i>		-0.68(0.00)	
Travel by motor cycle	-0.19(0.00)	-0.49(0.00)	.42(0.00)	.7(0.00)
Waiting time at the station	-0.055(.004)	<i>.045(.192)</i>	-0.31(0.00)	<i>.67(0.00)</i>
Time taken to reach the destination	-0.097(0.00)	<i>.91(0.00)</i>	<i>.1(0.00)</i>	<i>.33(0.00)</i>
Comfort level of the mode	<i>.987(0.00)</i>	-0.041(0.00)	<i>.32(.003)</i>	<i>.86(0.00)</i>
				<i>.78(0.00)</i>
<b>Latent Variables</b>				
Trip Characteristics	-	-	.992	-
Trip chain of work related days	-	-	.258	-
Trip chain of non-work related days	-	-	.611	-
Trip Behavior	-	.71	-	.0058
Trip chain	-	-	-	.068

Co-efficient of influencing variable are shown in Italic number.

**Table 5.3 Fit indices to determine the goodness of fit of different model**

<b>Fit Indices</b>	<b>Model 1</b>	<b>Model 2</b>	<b>Model 3</b>	<b>Model 4</b>
<b><u>Absolute fit indices</u></b>				
Root mean square of approximation (RMSEA)	0.092	0.00	0.00	0.00
Standardized root mean square residual (SRMR)	0.040	0.012	0.00	0.000
<b><u>Incremental fit indices</u></b>				
Comparative fit index (CFI)	0.823	1.00	1.00	1.00
Tucker-Lewis index (TLI)	0.725	0.758	0.824	0.95
<b><u>Parsimony fit indices</u></b>				
Akaike's information criterion (AIC)	34468.13	35906.74	35783.13	35872.14

### **5.2.5 Effect of heterogeneity on model performance**

The heterogeneity among users might affect choice of travel mode for the trip to work. The travel mode choice variables are not equally esteemed by the users; meaning that an improvement made to any of these variables would not have the same acceptance level from the individual users. This effect was examined by reevaluating the best model (M4). Specifically, the heterogeneity was considered by dividing the entire sample based on family monthly income range. This type of segmentation technique was followed by Chou et al. (2014) and Rahman et al. (2016) to analyze the effect of heterogeneity among users on their overall SQ perception and other facilities. The categorization is shown in Table 5.4. Interestingly, the heterogeneity analysis hardly shows any change in the parameter signs. However, it shows some variation in the parameter values for different user groups. Endogenous variables, parking availability, no non-work from home to work but more than two non-work stop from work to home trip, travel by private car, travel by motor cycle, comfort level of the mode identified by each heterogeneous user group remain the same as in M4 showing some alteration in their ranks.

**Table 5.4: Categorization to find the effect of heterogeneity**

Categorization	Sample Size
Family monthly income 20000-40000 (Taka)	430 (43% of total data)

Interestingly, for this user group, trip distance, change of mode, simple home to work-work to home trip, one non-work from home to work and one non-work stop from work to home trip, no non-work from home to work but one non-work stop from work to home trip, travel by bus/tempo, travel by bicycle/rickshaw, waiting time at the station, and time taken to reach the destination influences choice of travel mode for the trip to work negatively which does not match the real scenario. For maximum family monthly income group, the most significant variable is ‘trip distance’ and ‘change of mode’; whereas, people choose travel mode for the trip to work according to their monthly income range.

## CHAPTER 6

### CONCLUSION AND RECOMMENDATIONS

#### 6.1 General

Mode choice behavior is a fundamental element of travel behavior that has significant implications for transportation planning. Along with estimates of public transit ridership and the use of alternative modes of transportation, the effectiveness of policies regarding introduction of a new transit system or improvement of the existing one depends on studies of mode choice behavior and modal split models. These are the critical determinants of the probability of what factors will act behind the shifting of people from one mode to the other and also the probability of the number of people may actually change their travel mode. A series of structural equation models are developed to find the correlation between mode selection attributes and effects on the general mode selection. The goal is to identify which parameters are more important. The data was collected from different locations of Dhaka city. Mode choice behavior is analyzed with respect to users' socio-economic characteristics.

In this study effort has been made to investigate the relationship between mode choice attributes and trip chaining for Dhaka city. The users stated their preferences and those are used to find out the best positive parameters or set of parameters which affect the choice of mode. In this research, four models were developed by SEM and compared with the standardized values to find out the best model. Three out of four models are well fitted; all of which were developed with latent variables for instance trip characteristics, trip chains, and trip behavior. Moreover, SEM approach is found to be efficient for modeling mode choice in Dhaka determining the variables which play significant role in user satisfaction about the trips. In our study variables are shuffled for each model and best models are found out.

Model 2 explored that among three endogenous variables time taken to reach destination is the most influential attribute that affect the change of mode. In this model trip behavior is used as a latent variable and among the ten exogenous variables trip distance affect the latent variable most.

In model 3, three latent variables are introduced and they have very strong relationship among each other. Trip characteristics, trip chains in work related days and trip chains in non-work related days are introduced as a latent variable in model 3. In this model travel by bus/tempo are the main influential attributes while parking availability and waiting time at the station are the insignificant parameter.

For the final proposed model 4, it was revealed that all endogenous variables are positively related with latent variables. Two latent variables trip chain and trip behavior are introduced in this model. In model 4, travel by bus/tempo is the most influential variable. Comfort level of the mode and waiting time at the station is also important attribute of the model.

Mode choice always has a negative relationship with “waiting at stations” and “time to reach destination”. It is obvious that people feel frustrated in waiting at stations and also they want to reach their destination quickly. “Simple home to work and work to home” type trip chain has positive effect on the latent variable. Because this is a common type of trip chain for users in Dhaka city and also it takes short time. The results match with real world scenario. It is needed to take into account that all significant variables have a role in making trip chains and mode choice. Hence a clear perception about assessing users’ mode choice making according to their trip chains and household conditions is vital. The determination of the most and the least important trip chain and mode choice variables certainly helps to concentrate the limited resources of developing countries to improve users’ experience.



## 6.2 Summary

The main purpose of this research is to find out the attribute that affect the choice of travel mode for work trips in Dhaka city. We have carried out questionnaire survey at 14 locations in Dhaka city to 1000 respondents. According to field survey 96% of the respondents were male. 73% respondents were service holder which indicates the main occupation was service. 71% respondents were married. Most of the respondents were graduates, 43% of the respondents' age was within 31 to 40 years range. 35% of the respondents had no children, 42% of the respondents had two household adults in family. 34% of the respondents said that they had five or more family members in his/her family. 43% of the respondents had monthly family income within 20,000-40,000 taka. 55% of the respondents' working hour per day is 7 to 9 hours in a day. 69% of the respondents had no household motorized vehicle. Half of the respondents said that their workplace had no parking facility. 38% of the respondents had monthly household travel expenditure within 2000 to 5000 taka. 36% of the respondents said that the distance between homes to work place is within 1 to 3 km range. 79% of the respondents said that they didn't change any mode. The majority of the respondents said that they made h-w-(-w)-h trip chain of work related days. 68% of the respondents reported that they made h-nw-h trip chain in non-work related days. Half of the respondents reported that they made h-nw-(-nw)-h trip chain in non-work related days. 46% of the respondents said that they use bus/tempo as main mode of travel. Waiting time for a mode was 5 to 10 minutes which were reported by 34% of the respondents. 36% of the respondents' travel time was 30 minutes. 49% of the respondents said that comfort level of the mode was very uncomfortable.

From this study, it was revealed that the choice of different mode of transport for work trip depends on various socio-economic and transport service factors such as age, occupation, household size, income level, travel expenses, gender, comfort level of the mode, parking

availability etc. It was also revealed that waiting time at station, time to reach destination and comfort level of the mode and travel by bus/tempo are the main influential attributes to mode choice behavior in Dhaka city.

Trip makers usually do not like to change their mode of transport. Maximum trip makers make simple home to work; work to home h-w-(-w)-h trip chain in work related days. However, it is true that the choice of mode may vary time to time basing on overall transportation system and infrastructure development of the city. SEM approach is found to be efficient for modeling mode choice in Dhaka determining the variables which play significant role in user satisfaction about the trips. Out of four SE models the best SE model has been found with two latent variables. For the final proposed model, it was revealed that all endogenous variables are positively related with latent variables, trip chain and trip behavior. This proposed model had good fit indices and could explain actual scenario of mode choice attributes.

### **6.3 Limitations of the Study**

- i. The major limitation of this study is the sample size which is small relative to the number of users. Only 1000 respondents took part in this study.
- ii. The survey data is taken from 14 locations of Dhaka city. This obviously does not represent equal proportion of socio-economic groups in the study area.
- iii. Collected data may not represent users' actual choice of travel mode at pick hour in Dhaka city.
- iv. The survey was carried out at open places or junction points of various roads which may not represent the appropriate demographics information of respondents in Dhaka city. Due to safety reasons people of Dhaka city are not enthusiastic for household survey.

#### **6.4 Recommendations for Future Study**

Following are the few recommendations for future research study:

- i. The best suited model (model-4) may be helpful for future transportation planning in Dhaka City.
- ii. The major research opportunity with the mode choice model proposed in the study is to exploit it as a sub-model in developing travel demand model for future.
- iii. Route specific and user specific mode choice attributes can be analyzed in details using the same approach.
- iv. Several statistical models can be developed for future understanding of mode choice behavior of work trips.

## REFERENCES

- Aditjandra, P. T., Cao, X. J., and Mulley, C. (2012). Understanding neighborhood design impact on travel behaviour: An application of structural equations model to a British metropolitan data. *Transportation research part A: policy and practice*, 46(1), 22-32.
- Adler, T., and M. Ben-Akiva. (1979). A Theoretical and Empirical Model of Trip Chaining Behavior. *Journal of Transportation Research B*, Vol. 13, No. 3, pp. 243-257.
- Aftabuzzaman, M., Murumachi, Y., Harata, N., Ohta, K. (2010). Modeling Mode Choice Behavior for Work-trip of a Developing City”, Available at [www.ut.utokyo.ac.jp/research/2010/olmd.pdf](http://www.ut.utokyo.ac.jp/research/2010/olmd.pdf).
- Anas, A. (1983). Discrete choice theory, information theory and the multinomial logit and gravity models. *Transportation Research Part B, Methodological*, 17(1), 13-23.
- Anna-Lena Lindstrom Olsson (2003). Factors that Influence Choice of Travel Mode in Major Urban Areas (Page: 20-25).
- Ara, H. (1983). Socio-Economic Correlates of Urban Travel Pattern: A Study in Dhaka City. M.Sc. Thesis, Department of Urban and Regional Planning, BUET, Dhaka.
- Andaleeb, S.S., Haq, M., Ahmed, R.I., 2007. Reforming inner-city bus transportation in a developing country: a passenger-driven Model. *J. Pub. Transp.* 10 (1), 1–25.
- Bagley, M. N., & Mokhtarian, P. L. (2002). The impact of residential neighborhood type on travel behavior: A structural equations modeling approach. *The Annals of Regional Science*, 36(2), 279–297. <https://doi.org/10.1007/s001680200083>
- Bari, M. F., & Hasan, M. (2001). Effect of Urbanization on Storm Runoff Characteristics of Dhaka City. In XXIX IAHR Congress. Beijing. Tsinghua University Press.
- Ben-Akiva, M., & Berlaire, M. (1999). Discrete Choice Methods and Their Applications to Short-term Travel Decisions. In *Handbook of Transportation Science*. Hall, R. (ed.), International Series in Operations Research and Management Science.
- Ben-Akiva, M., & Lerman, S. R. (1985). *Discrete Choice Analysis: Theory and Application to Travel Demand*. MIT Press, Cambridge, Massachusetts.
- Bhat, C. R., Hensher, D. A., & Button, K. J. (2000). *Handbook of Transport Modelling*. (Button & Hensher, Eds.). Elsevier Science Ltd., Oxford, U.K.
- Bhat, C.R. (1997) Work Travel Mode Choice and Number of Non-work Commute Stops. *Journal of Transportation Research B*, Vol. 31, No. 1, pp. 41–54.
- Boomsma, A. (1985). Nonconvergence, improper solutions, and starting values in LISREL maximum likelihood estimation. *Psychometrika*, 50(2), 229-242.
- Bordagaray, M., Ibeas, A. and Cecín, P. (2014). Modelling user perception of bus transit quality considering user and service heterogeneity. *Transport metrica A, Transport Science*, 10(8), 705–721.
- Brown, C. H. (1993). Analyzing preventive trials with generalized additive models. *American Journal of Community Psychology*, 21(5), 635-664.

Browne, M.W., Cudeck, R. (1993). Alternative way so assessing model fit. Sage Focus Ed.154,136–136.

Brockerhoff, M. P. (2000). An Urbanizing World. *Population Bulletin*, 55(3), 1–44. <https://doi.org/10.1086/452394>

Currie, G., and Delbosc, A. (2011). Exploring the trip chaining behaviour of public transport users in Melbourne. *Transport Policy*, 18(1), 204-210.

Chen, J. X. (2007). Travel Demand Modeling Software Evaluation. In the SCAG Modeling Task Force Meeting.

Chou, P. F., Lu, C. S., & Chang, Y. H. (2014). Effects of service quality and customer satisfaction on customer loyalty in high-speed rail services in Taiwan. *Transportmetrica A: Transport Science*, 10(10), 917-945.

Ding, L., and Zhang, N. (2016). A Travel Mode Choice Model Using Individual Grouping Based on Cluster Analysis. *Procedia Engineering*, 137, 786-795.

Domencich, T. A., & McFadden, D. (1975). *Urban Travel Demand: A Behavioral Analysis*. North-Holland, Amsterdam.

Environment Protection Training & Research Institute, Hyderabad (2005).

Fuji, S. and Kitamura, R. (2000). Evaluation of Trip-inducing Effects of New Freeways Using a Structural Equations Model System of Commuters' Time use and Travel, *Transportation Research B*34, pp. 339-354.

Gebeyehu, M., & Takano, S. (2007). Diagnostic Evaluation of Public Transportation Mode Choice in Addis Ababa. *Journal of Public Transportation*, Vol. 10, No. 4, Pp. 27- 50.

Golob, T.F. R. Kitamura and C. Lula (1994). Modeling the Effects of Commuting Time on Activity Duration and Non-Work Travel. Presented at Annual Meeting of Transportation Research Board, Washington, D.C.

Golob, T.F. and McNally, M.G. (1997) A Model of Activity Participation and Travel Interactions Between Household Heads, *Transportation Research B*31(3), pp. 177-194.

Golob, T.F (2000). A Simultaneous Model of Household Activity Participation and Trip Chain Generation. *Transportation Research B*34, pp. 355-376.

Gopinath, D. A. (1995). Modeling heterogeneity in discrete choice processes: Application to travel demand, PhD thesis, Massachusetts Institute of Technology.

Habib, K. M. N. (2002). Evaluation of planning options to alleviate traffic congestion and resulting air pollution in Dhaka City. Department of Civil Engineering, 1-157.

Habib, N.K., Day, N., Miller, E.J. (2009). An investigation of commuting trip timing and mode Choice in the Greater Toronto Area: application of a joint discrete -continuous model. *Transp. Res. A* 43(7), 639–653.

Hadiuzzaman M., Farazi N., Hossain S., Malik G., (2017): An exploratory analysis of observed and latent variables affecting intercity train service quality in developing countries. *Transportation* <https://doi.org/10.1007/s11116-017-9843-6>

Hadiuzzaman M., Farazi N., Hossain S., Barua S., Rahman F. (2019) Structural Equation Approach to Investigate Trip-chaining and Mode Choice Relationships in the Context of Developing Countries. *Journal of Transportation Planning and Technology*, Volume 42, Issue 4.

Hasan, S. (2007). Development of A Travel Demand Model for Dhaka City. M.Sc. Thesis, Department of Civil Engineering, BUET, Dhaka.

Hensher, D. A., & Button, K. J. (Eds. .2000). *Handbooks of Transport*. Elsevier Science Ltd., Oxford, U.K.

Hensher, D. A., and Reyes, A. J. (2000). Trip Chaining as a Barrier to the Propensity to Use Public Transport. *Transportation*, 27, 341–361.

Hooper, D., Coughlan, J., & Mullen, M. (2008). Structural equation modelling: Guidelines for determining model fit. *Articles*, 2.

Ho, E. P., Lu, X., Li, J., & Xue, M. (1999). An Urban Transportation Planning Model for Shanghai-A City with Rapid Economic Growth and Urban Development. In *Conference on the Application of Transportation Planning Methods* (p. 282).

Horowitz, J. L., Koppelman, F. S., & Lerman, S. R. (1986). A Self-instructing Course in Disaggregate Mode Choice Modeling. Final Report (No. UMTA-IA-11-0006-86-1).

Jöreskog, K. G. (1973). Analysis of covariance structures. In *Multivariate Analysis–III Proceedings of the Third International Symposium on Multivariate Analysis Held at Wright State University, Dayton, Ohio, June 19–24*, Pages 263-285.

Karim, M. M. (1998). Mass transit and appropriate measures in Dhaka metropolitan. In *Proceedings of 91st Annual Meeting of A&WNA (Vol. 17)*.

Karlaftis, M. G., Golias, J., and Papadimitriou, E. (2001). Transit quality as an integrated traffic management strategy: Measuring perceived service. *Journal of Public Transportation*, 4(1).

Koppelman, F. S., & Bhat, C. R. (2006). A Self Instructing Course in Mode Choice Modeling: Multinomial and Nested Logit Models. *ResearchGate*, Article June-2006.

Khan M., Hadiuzzaman M., Das T., Rahman F., Shimu T., (2018): A Structural Equation Approach in Modeling Perceived Service Quality of Passenger Ferry. *Management Research and Practice*, Volume10, Issue1.

Kuppam, A. R., & Pendyala, R. M. (2000, January). An exploratory analysis of Commuters activity and travel patterns. In 79th „Annual Meeting of the Transportation Research Board“, Washington, DC.

Kitamura, R., J. P. Robinson, T.F. Golob, M. A. Bradley, J. Leonard and T. van der Hoorn (1992). A comparative analysis of time use data in the Netherlands and California.

In Proceedings of the 20<sup>th</sup> PTRC Summer Annual Meeting: Transportation Planning Methods, pp. 127-138.

Kitamura, R. (1996). Activity-based travel demand forecasting and policy analysis. Presented at the TMIP Conference on Activity-Based Travel Forecasting, New Orleans, LA.

Kitamura, R., Yamamoto, T., Susilo, Y. O., & Axhausen, K. W. (2006). How routine is a routine? An analysis of the day-to-day variability in prism vertex location. *Transportation Research Part A: Policy and Practice*, 40(3), 259-279.

Kwakye, E. A., Fouracre, P. R., & Oforu-Dorte, D. (1997). Developing strategies to meet the transport needs of the urban poor in Ghana. In *World Transport Policy & Practice* (Vol. 3, pp. 8-14).

Liu, G. (2006). A Behavioral Model of Work-Trip Mode Choice in Shanghai. Statistics Norway, Research Department, Discussion Paper No. 444.

Luce, R. Duncan. (1959). *Individual choice behavior: a theoretical analysis*. New York: Wiley.

MacCallum, R. C., Widaman, K. F., Zhang, S., & Hong, S. (1999). Sample size in factor analysis. *Psychological methods*, 4(1), 84.

MacCallum, R. C., & Austin, J. T. (2000). Applications of structural equation modeling in psychological research. *Annual review of psychology*, 51(1), 201-226.

MacDonald, H. I. (1999). Women's employment and commuting: explaining the links. *Journal of Planning Literature*, 13(3), 267-283.

Manski, Charles F (1973). *The Analysis of Qualitative Choice*. Ph.D. Dissertation, Department of Economics, MIT, Cambridge, Massachusetts.

Marschak, J., Arrow, K., Karlin, S., & Suppes, P. (1960). *Stanford symposium on mathematical methods in the social sciences*.

Meka, S. (2003). A Structural Equations Analysis of Within-Household Activity and Time Allocation Between Two Adults, Master Thesis, Department of Civil and Environmental Engineering, University of South Florida, Tampa, FL.

McFadden, D., Talvitie, A., Cosslett, S., Hasan, I., Johnson, M., Reid, F., & Train, K. (1977). Demand model estimation and validation. *Urban Travel Demand Forecasting Project, Phase, 1*. Retrieved from <http://www.econ.berkeley.edu/wp/utdfp/vol5/front.pdf>

Meyer, M. D., & Miller, E. J. (2001). *Urban Transportation Planning: A Decision-Oriented Approach*. New York: McGraw Hill.

Nurdeen, A., Rahmat R., Ismail, A. (2007). Modeling of Transportation Behavior for Coercive Measures for Car Driving in Kuala Lumpur. *ARNP Journal of Engineering and Applied Sciences*, Vol. 2, No. 2, April.

Olsson, A. L. (2003). Factors that Influence Choice of Travel Mode in Major Urban Areas. The attractiveness of park & ride. *Trita-infra*, (03-048).

Ortúzar, J. D. D., & Willumsen, L. G. (2001). *Modeling Transport*. 3rd. New York: John Wiley & Sons Ltd.

Kline, R. B. (2005). *Principles and practice of structural equation modeling: Methodology in the social sciences*.

Rahman, F., Das, T., Hadiuzzaman, M., & Hossain, S (2016). Perceived service quality of paratransit in developing countries: A structural equation approach. *Transportation Research Part A: Policy and Practice*. *Transp. Res. Part A Policy Pract.* 93.

Rahman, S. (2008). Understanding the Linkages of Travel Behavior with Socioeconomic Characteristics and Spatial Environments in Dhaka City and Urban Transport Policy Applications, (September).

Rodrigue, J. P., Comtois, C., & Slack, B. (2009). *The Geography of Transport System (Second)*. New York, Routledge.

Strathman, J.G., K.J. Dueker, and J.S. Davis.(1994). Effects of Household Structure and Selected Travel Characteristics on Trip Chaining. *Transportation*, Vol.21, No.1,pp.23-45.

Strathman, J. G., and Dueker, K. J. (1995). Understanding trip chaining. Special reports on trip and vehicle attributes, 1990 NPTS reports series, publication No. FHWA-PL-95-033, Department of transportation.

STP (2005). *Strategic Transport Plan for Dhaka*, Prepared by Louis Berger Group and Bangladesh Consultant Ltd.

Steiger, J. H. (1990). Structural model evaluation and modification: An interval estimation approach. *Multivariate behavioral research*, 25(2), 173-180

Schakenbos, R., L. La Paix, S. Nijenstein, K.T.Geurs (2016). Valuation of a transfer in A multimodal public transport trip. *Transport Policy*, 46, 72-81.

Schmöcker, J., F. Su, and R.B. Noland.(2010). An Analysis of Trip Chaining among Older London Residents. *Transportation*, Vol. 37, No. 1, pp. 105-123.

Simma, A., and Axhausen, K. (2001). Within-household allocation of travel: Case of upper Austria. *Transportation Research Record: Journal of the Transportation Research Board*, (1752), 69-75.

Small, K. A. (2005). *Fundamentals of Economic Demand Modeling: Lessons from Travel Demand Analysis*. In *Decision-Based Design: Making Effective Decisions in Product and Systems Design*. ASME Press.

Shifan, Y., Out water, M. L., and Zhou, Y. (2008). Transit market research using structural equation modeling and attitudinal market segmentation. *Transport Policy*, 15(3), 186-195.



Srinivasan, S., & Rogers, P. (2005). Travel Behavior of Low-Income Residents: Studying Two Contrasting Locations in the City of Chennai, India. *Journal of Transport Geography* 13, Pp. 265-274.

Stopher, P. R., & Meyburg., A. H. (1975). Urban transportation modeling and planning. TRID- the TRIS and ITRD database.

Takyi, I. K. (1990). Trip Generation Analysis in a Developing Country Context. In *Transportation Research Record* (pp. 9–21). Washington DC: TRB, National Research Council.

Thurston, L. (1927). In *A Law of Comparative Judgment*. *Psychology Review*, 34 (1927): 273-286.

Timmermans, H., van der Waerden, P., Alves, M., Polak, J., Ellis, S., Harvey, A. S., ...& Zandee, R. (2003). Spatial context and the complexity of daily travel patterns: an international comparison. *Journal of Transport Geography*, 11(1), 37-46.

Train, K. (1998). Recreation Demand Models with Taste Differences over People. *Land Economics*, vol. 74, pp. 230-240.

Train, K. E. (2003). *Discrete Choice Methods with Simulation*. Cambridge University Press.

Train, K. E., & McFadden, D. (1978). The goods/leisure tradeoff and disaggregate work trip mode choice models. *Transportation Research*, 12(5), 349–353. [https://doi.org/http://dx.doi.org/10.1016/0041-1647\(78\)90011-4](https://doi.org/http://dx.doi.org/10.1016/0041-1647(78)90011-4)

Wallin Andreassen, T. (1995). (Dis) satisfaction with public services: the case of public transportation. *Journal of Services Marketing*, 9(5), 30-41.

Walker, J. L. (2001). *Extended discrete choice models: integrated framework, flexible error structures, and latent variables* (Doctoral dissertation, Massachusetts Institute of Technology).

Wiley, D. E., Seminar Press, Inc, & United States of America. (1973). The identification problem for structural equation models with unmeasured variables, *Structural Equation Models in the Social Science*. 69-83.

Ye, X., Pendyala, R. M., & Gottardi, G. (2007). An exploration of the relationship between mode choice and complexity of trip chaining patterns. *Transportation Research Part B: Methodological*, 41(1), 96-113.

Yun, M. P., Chen, Z. H., & Liu, J. Y. (2014). *Comparison of mode choice behavior for work tours and non-work tours considering trip chain complexity* (No. 14-0610).

ZHANG, J., FUJIWARA, A., & THEIN, S. (2008). Capturing Travelers' Stated Mode Choice Preferences Under Influence of Income in Yangon City, Myanmar. *Journal of Transportation Systems Engineering and Information Technology*, 8(4), 49-62.

## APPENDIX A

### PHOTOGRAPHS OF OVERALL SURVEY



Photograph A-1: Surveying at Dhanmondi 7 & 8, Green road, Mirpur road



Photograph A-2: Surveying at Nilkhet and Newmarket



Photograph A-3: Surveying at Jigatola Bus Stand



Photograph A-4: Surveying at Dhanmondi 15



Photograph A-5: Surveying at Panthopath signal



Photograph A-6: Surveying at Karwan Bazar



Photograph A-7: Surveying at Farmgate



Photograph A-8: Surveying at Kalabagan



Photograph A-9: Surveying at Shukrabad/ Dhanmondi 32



Photograph A-10: Surveying at Mohammadpur Bus Stand



Photograph A-11: Surveying at Shyamoli



Photograph A-12: Surveying at Dhanmondi 27 Bus Stand



Photograph A-13: Surveying at Asadgate Bus Stand



Photograph A-14: Surveying at Gulshan 2

**APPENDIX B**  
**SURVEY QUESTIONNAIRES**

Occupation:

Age:

Location:

---

1. Gender:     I) Male     II) Female
  
2. Marital Status?
  - a. Married
  - b. Single
  
3. What is your educational qualification?
  - a. Under elementary
  - b. Elementary/ Diploma/ Intermediate
  - c. Graduate/ Post Graduate
  - d. Doctoral Degree
  - e. No education
  
4. How many members are there in your family?
  - a. 1

- b. 2
  - c. 3
  - d. 4 or more
5. What is your monthly family Income?
- a. Less than 5000
  - b. 5000-10000
  - c. 10000-20000
  - d. 20000-40000
  - e. More than 40000
6. What is condition parking facilities at working place?
- a. Excellent
  - b. Very good
  - c. Good
  - d. Moderate
  - e. No parking facilities
7. How much time do you have to wait at the station for the mode?
- a. Less than 5 min
  - b. 5-10 min
  - c. 10-15 min
  - d. More than 15 min



8. How much time does it take to reach by this mode?
- a. 10 min
  - b. 20 min
  - c. 30 min
  - d. 1 hour
  - e. More than 1 hour
9. How long is the distance of your trip from your house?
- a. less than 1 km
  - b. 1-3 km
  - c. 3-5 km
  - d. Above 5 km
10. How many times do you have to change to reach the mode?
- a. 1 time
  - b. 2 time
  - c. 3 time
  - d. 4 time
  - e. More than 4 time
11. What is the purpose of the trip?
- a. School

- b. Work place
  - c. Store/ shopping mall
  - d. Others
12. Which mode do you use for this purpose?
- a. Bus/ Tempo
  - b. Car
  - c. Taxi/ Three Wheeler
  - d. Rickshaw/ walk/ bicycle
  - e. Motor cycle
13. How much is your travelling fare by this mode?
- a. Less than 2 taka
  - b. 3 to 4 taka
  - c. 5 to 6 taka
  - d. 7 to 8 taka
  - e. More than 8 taka
14. Why do you choose this mode for the trip?
- a. Have no other options
  - b. Cheaper than other options
  - c. Safer than other options
  - d. Is more flexible

- e. Faster than other options
15. Is there any other option for this trip?
- a. Bus/ Laguna/ tempo
  - b. Car
  - c. Taxi/ three wheeler
  - d. Rickshaw/ walk
  - e. Motor cycle
16. Why are you not using the other option?
- a. Takes too time
  - b. Costly
  - c. Discomfort
17. How much do you travel in this route?
- a. Regular
  - b. Weekly
  - c. Monthly
  - d. Sometime
  - e. Often
18. How is the comfortable level of the mode?
- a. Excellent
  - b. More comfortable

- c. Comfortable
  - d. Less comfortable
  - e. Very less comfortable
19. How many motorized vehicles are there in your household?
- a. 1
  - b. 2
  - c. 3 or more
  - d. none
20. What is the monthly household travel Expenditure?
- a. Less than 500
  - b. 500-2000
  - c. 3000-5000
  - d. 6000-10000
  - e. Above 10000